

MOUNTING INSTRUCTION

2026-03-20 38-368400a

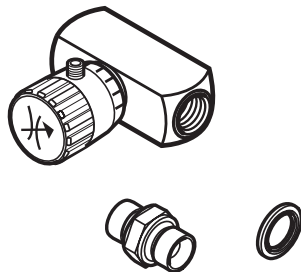

- DE Durchflussregelungsventilsatz
URSP 180-2
- DK Sæt med flowstyringsventil
URSP 180-2
- EE Voolu regulaatorklapi komplekt
URSP 180-2
- FI Virtauksensäätöventtiilisarja
URSP 180-2
- FR Kit de vanne de régulation de
débit URSP 180-2
- GB Flow control valve kit
URSP 180-2

- LV Plūsmas regulēšanas vārstu
komplekts URSP 180-2
- NL Set debietregelklep
URSP 180-2
- NO Volumstrømventilsett
URSP 180-2
- PL Zestaw zaworów regulujących przepływ
URSP 180-2
- RU Комплект регулирования клапана
расхода URSP 180-2
- SE Flödesventilsats
URSP 180-2



Montageanleitung
 Monteringvejledning
 Paigaldusjuhend
 Asennusohje

Instructions de montage
 Mounting instruction
 Montāžas instrukcija
 Montagehandleiding

Monteringsanvisning
 Instrukcja montażowa
 Указания по монтажу
 Monteringsanvisning



Demontage
 Afmontering
 Demonteerimine
 Purkaminen

Démontage
 Dismantling
 Demontāža
 Demontage

Demontering
 Demontaž
 Демонтаж
 Demontering

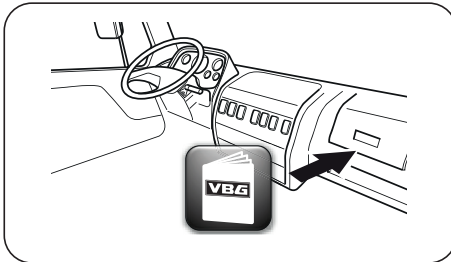
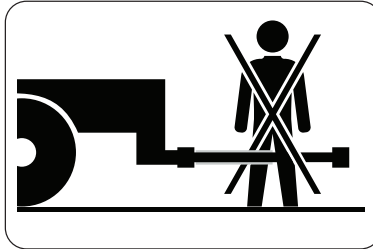

21-875900

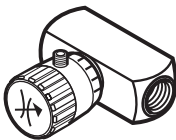

x1



x1



x1

DE

Allgemeines

Identifizieren Sie vor der Montage alle Teile. Montage und Wartung müssen genau und fachmännisch durchgeführt werden. Befolgen Sie die Anweisungen.

VBG GROUP TRUCK EQUIPMENT AB behält sich technische Änderungen vor.

DK

Generelt

Identificér alle dele før montering. Montering og service skal udføres på en omhyggelig og fagligt korrekt måde. Følg vejledningen.

VBG GROUP TRUCK EQUIPMENT AB forbeholder sig retten til konstruktionsændringer.

EE

Üldist

Määratlege kõik osad enne monteerimist. Paigaldus ja hooldus tuleb teostada hoolikalt ja professionaalselt. Järgige juhiseid.

VBG GROUP TRUCK EQUIPMENT AB jätab endale õiguse konstruksioonimuudatusteks.

FI

Yleistä

Tunnista kaikki osat ennen asennusta. Asennus ja huolto on suoritettava huolellisesti ja ammattimaisesti. Noudata ohjeita.

VBG GROUP TRUCK EQUIPMENT AB pidättää oikeuden rakennemuutoksiin.

FR

Généralités

Identifier toutes les pièces avant le montage. Le montage et l'entretien doivent être effectués avec le plus grand soin et selon des méthodes de professionnels. Suivre les instructions.

VBG GROUP TRUCK EQUIPMENT AB se réserve le droit de modifier sans préavis la conception de ses produits.

GB

Description

Identify all parts before use. Installation and maintenance should be carried out in the correct and approved way. Always follow the instructions.

VBG GROUP TRUCK EQUIPMENT AB reserve the right to change design specifications without prior notice.

LV

Vispārīga informācija

Pirms montāžas identificējiet visas detaļas. Montāža un serviss ir jāveic rūpīgi un profesionāli. Sekojiet norādījumiem.

VBG GROUP TRUCK EQUIPMENT AB saglabā tiesības izdarīt izmaiņas izstrādājumu konstrukcijās.

NL

Algemeen

Voor de montage moet u alle onderdelen identificeren. Voer montage en service zorgvuldig en deskundig uit. Volg de instructies.

VBG GROUP TRUCK EQUIPMENT AB behoudt zich het recht voor op constructiewijzigingen.

NO

Generelt

Identifiser alle deler før montering. Montering og service skal utføres nøyaktig og fagmessig. Følg anvisningene.

VBG GROUP TRUCK EQUIPMENT AB forbeholder seg retten til konstruksjonsendringer.

PL

Informacje ogólne

Zapoznaj się z poszczególnymi częściami przed przystąpieniem do montażu. Czynności montażowe i serwisowe należy wykonywać dokładnie i fachowo. Stosuj się do instrukcji.

VBG GROUP TRUCK EQUIPMENT AB zastrzega sobie prawo wprowadzania zmian produktów bez uprzedzenia.

RU

Общая информация

Перед монтажом проверьте наличие всех деталей. Монтаж и обслуживание должны осуществляться тщательно и профессионально. Следуйте указаниям.

Компания VBG GROUP TRUCK EQUIPMENT AB сохраняет за собой право на изменения в конструкции.

SE

Allmänt

Identifiera alla delar före montering. Montering och service skall utföras noggrant och fackmannamässigt. Följ anvisningarna.

VBG GROUP TRUCK EQUIPMENT AB förbehåller sig rätten till konstruktionsförändringar.



1.



2.

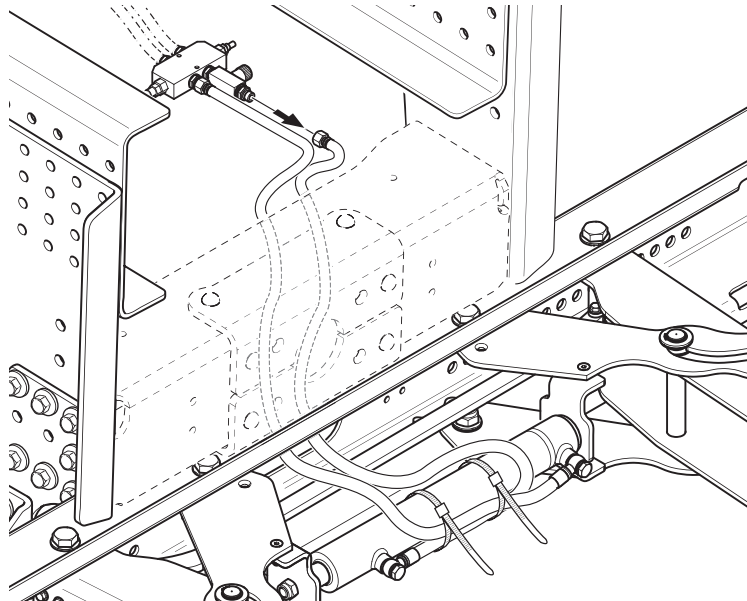

3.

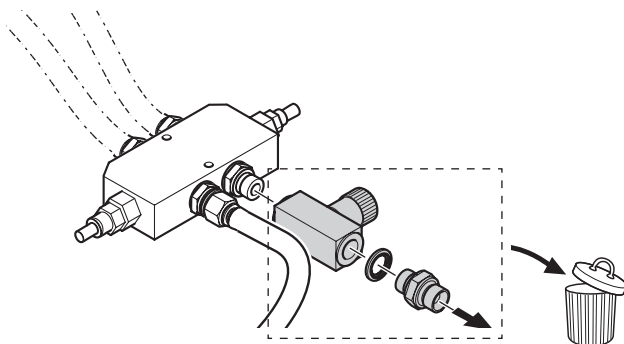



1.

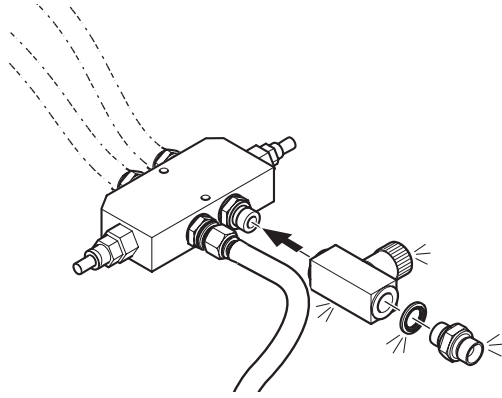

2.

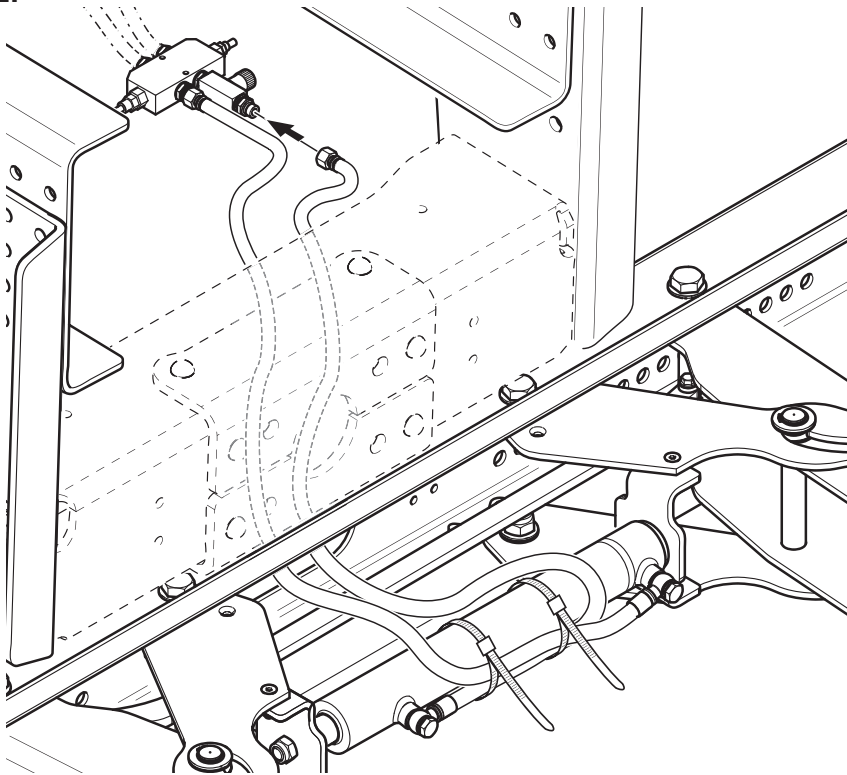



140-150 bar



3.

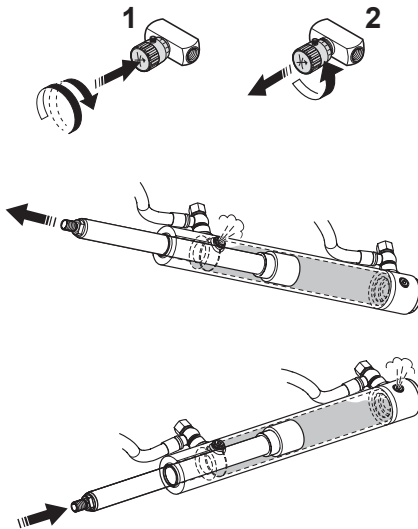

↔
↔
x 2

4.

