

# MOUNTING INSTRUCTION

2025-02-24 38-31600f

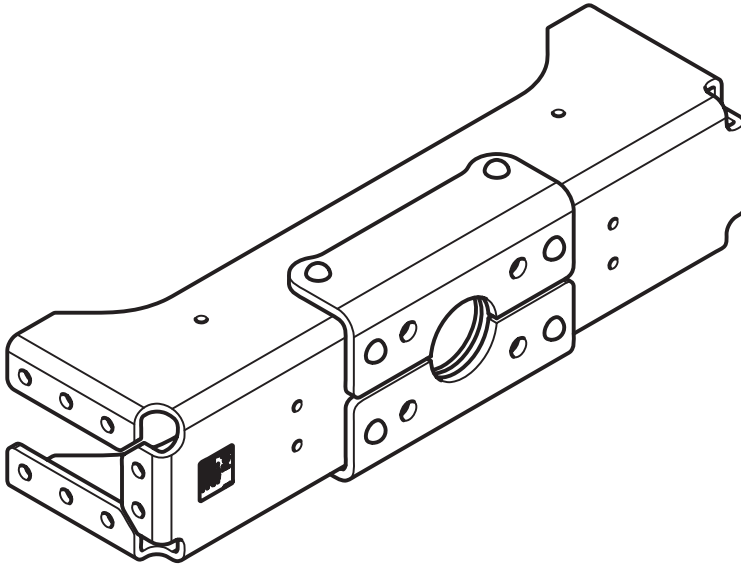

## 21-617400



- 
- |           |  |           |   |
|-----------|--|-----------|---|
| <b>DE</b> | Traversen DB75V-3 und Seitenplatten            | <b>LV</b> | Vilcējspriaišļa DB75V-3 un stiprinājuma plākšņu komplekts |
| <b>DK</b> | Trækbjælke DB75V-3 og gavlsæt                  | <b>NL</b> | Trekbalk DB75V-3 en zijplaten                             |
| <b>EE</b> | Veotala DB75V-3 ja otsakinnituse komplektid    | <b>NO</b> | Trekkbjelke DB75V-3 og gavelsatser                        |
| <b>FI</b> | Vetopalkin DB75V-3 ja sivulevyt                | <b>PL</b> | Belka zaczepowa DB75V-3 i płyty montażowe                 |
| <b>FR</b> | Traverse d'attelage DB75V-3 et jeux de flasque | <b>RU</b> | Тяговая балка DB75V-3 и фронтонные комплекты              |
| <b>GB</b> | Drawbeam DB75V-3 and End Plates                | <b>SE</b> | Dragbalk DB75V-3 och gavelsatser                          |



Montageanleitung  
Monteringvejledning  
Paigaldusjuhend  
Asennusohje

Instructions de montage  
Mounting instruction  
Montāžas instrukcija  
Montagehandleiding

Monteringsanvisning  
Instrukcja montażowa  
Указания по монтажу  
Monteringsanvisning

DE

## Allgemeines

Identifizieren Sie vor der Montage alle Teile. Montage und Wartung müssen genau und fachmännisch durchgeführt werden. Die Anweisungen und etwaigen Rahmenver-stärkungen des Fahr-zeugherstellers müssen beachtet werden. Übergeben Sie alle Anweisungen und Anleitungen dem Kunden, damit dieser die Unterlagen für spätere Wartung und Pflege im Fahrzeug verwahren kann. Weitere Informationen finden Sie auf unserer Homepage: [www.vbg.eu](http://www.vbg.eu).

DK

## Generelt

Identificer alle dele før montering. Montering og service skal udføres omhyggeligt og på en faglig korrekt måde. Bemærk at der skal tages hensyn til bilfabrikantens vejledninger og eventuelle ramme-forstærkninger. Giv kunden alle anvisninger og instruktioner, så de kan opbevares i bilen med henblik på fremtidig service og vedligeholdelse. Yderligere information findes på vores hjemmeside [www.vbg.eu](http://www.vbg.eu).

EE

## Üldist

Identifitseerige enne montaaži kõik osad. Paigaldus ja hooldus tuleb teostada hoolikalt ja professionaalselt. Pange tähele, et arvesse tuleb võtta ka sõiduki tootja juhiseid ja võimalikke ettekirjutusi raamitugevduste osas. Andke juhi käsiraamat kliendile kaasa sõidukis säilitamiseks, et see oleks käepärast hilisemate hoolduste korral. Täiendava teabe saamiseks külastage meie kodulehte [www.vbg.eu](http://www.vbg.eu).

FI

## Yleistä

Tarkasta kaikki osat ennen asennusta. Asennus ja huolto tulee tehdä huolellisesti ja ammattitaidolla. Huomioi ajoneuvon valmistajan ohjeet asennuksesta ja mahdollisista vahvistuksista. Luovuta kaikki ohjeet asiakkaalle ajoneuvossa säilytettäväksi tulevia huoltoja ja kunnossapittoa varten. Lisätietoja löytyy kotisivuiltamme [www.vbg.eu](http://www.vbg.eu).

FR

## Généralités

Identifier toutes les pièces avant le montage. Le montage et l'entretien doivent être effectués avec le plus grand soin et selon les instructions recommandées. Observer que les instructions du constructeur du véhicule et les éventuels renforts du cadre doivent impérativement être respectés. Remettre toute la documentation au client. Elle doit être conservée dans le véhicule pour les entretiens et maintenances ultérieurs. Pour plus d'informations, consultez notre site Web [www.vbg.eu](http://www.vbg.eu).

GB

## General

Identify all parts before installation. Installation shall be done in a proper and competent manner. The truck manufacturer's body building instructions must be observed. All directives and instructions should be kept in the vehicle for future service and maintenance. For more information, go to our website: [www.vbg.eu](http://www.vbg.eu).

LV

## Vispārēja informācija

Pirms uzstādīšanas identificējiet visas detaļas. Uzstādīšana veicama rūpīgi un kompetenti. Jāievēro kravas automašīnas ražotāja korpusa montāžas instrukcijas. Visus norādījumus un instrukcijas, kas būs nepieciešamas servisam un apkopei, nododiet klientam, lai tās tiktu uzglabātas transporta līdzeklī. Lai saņemtu vairāk informācijas, skatiet mūsu mājaslapu [www.vbg.eu](http://www.vbg.eu)

NL

## Algemeen

Voor de montage moet u alle onderdelen identificeren. Voer montage en service zorgvuldig en deskundig uit. Let op dat rekening moet worden gehouden met de aanwijzingen van de voertuigfabrikant en eventuele chassisverstevingen. Laat de klant alle aanwijzingen en instructies in het voertuig bewaren, zodat deze voor toekomstige service en onderhoud beschikbaar zijn. Ga voor meer informatie naar onze website [www.vbg.eu](http://www.vbg.eu).

---

**NO**

## Generelt

Identifiser alle deler før montering. Montering og service skal utføres nøyaktig og fagmessig. Observer at det må tas hensyn til kjøretøyproduzentens anvisninger og eventuelle rammeforsterkninger. Overlever alle anvisninger og instruksjoner til kunden for oppbevaring i kjøretøyet for fremtidig service og vedlikehold. Gå til hjemmesiden vår, [www.vbg.eu](http://www.vbg.eu), for mer informasjon.

**PL**

## Informacje ogólne

Zapoznaj się z poszczególnymi częściami przed przystąpieniem do montażu. Czynności montażowe i serwisowe należy wykonywać dokładnie i fachowo. Zauważ, że konieczne jest stosowanie się do instrukcji producenta pojazdu oraz uwzględnienie ewentualnych wzmocnień ramy. Wszystkie wskazówki i instrukcje należy przekazać klientowi w celu przechowywania ich w pojeździe do wykorzystania przy okazji przyszłych czynności serwisowych i konserwacyjnych. Dodatkowe informacje znajdują się na naszych stronach internetowych [www.vbg.eu](http://www.vbg.eu).

**RU**

## Общая информация

Перед монтажом, проверьте наличие всех деталей. Монтаж и обслуживание должны осуществляться тщательно и профессионально. Заметьте, что должны учитываться и приниматься во внимание возможные усиления рамы, сделанные изготовителем транспортного средства. Передайте клиенту все указания и инструкции для хранения их в машине для обслуживания и сервисных работ в будущем. Для получения дополнительной информации, посетите наш веб-сайт [www.vbg.eu](http://www.vbg.eu).

**SE**

## Allmänt

Identifiera alla delar före montering. Montering och service skall utföras noggrant och fackmannamässigt. Notera att fordonstillverkarens anvisningar och eventuella ramförstärkningar måste beaktas. Lämna alla anvisningar och instruktioner till kunden att förvaras i fordonet för framtida service och underhåll. För mer information, gå in på vår hemsida [www.vbg.eu](http://www.vbg.eu).

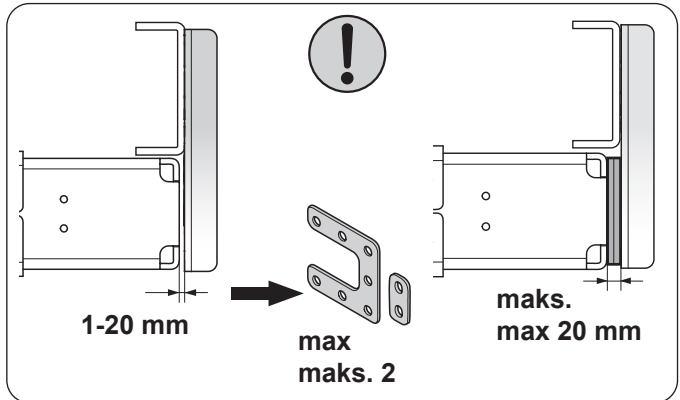
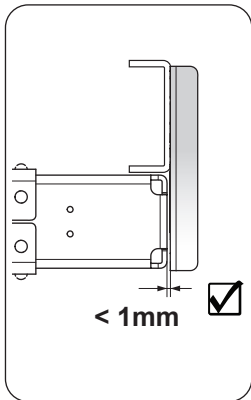
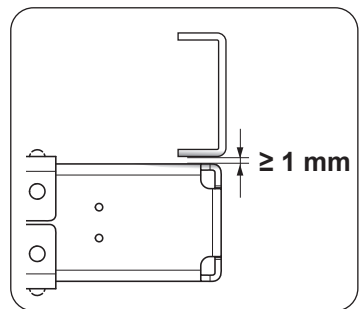
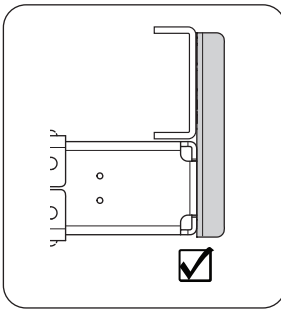
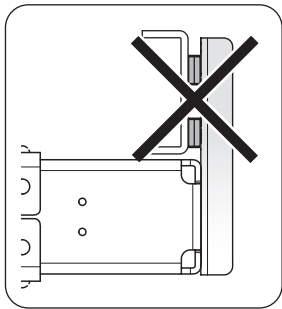
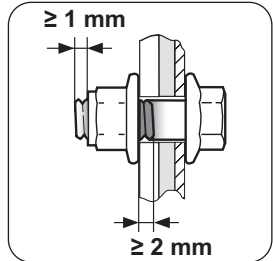
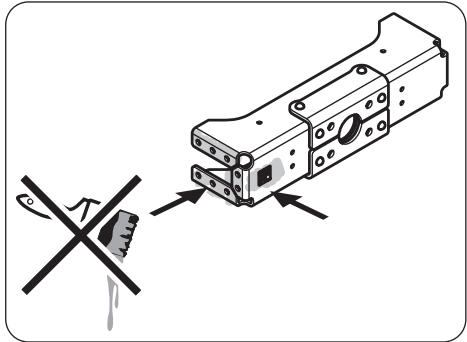
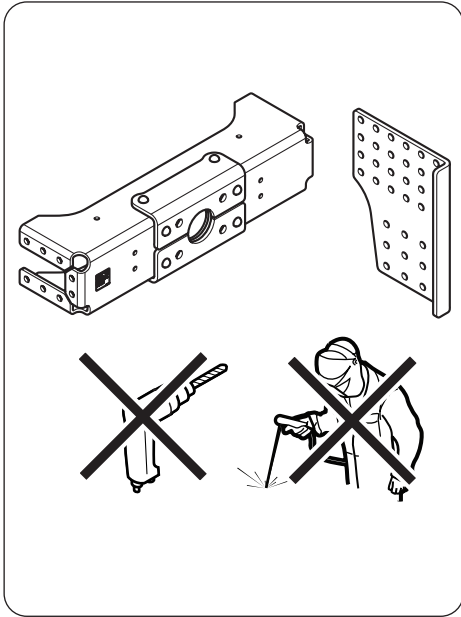

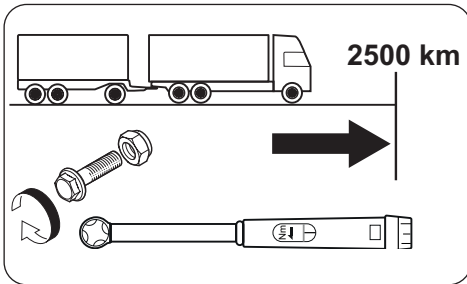
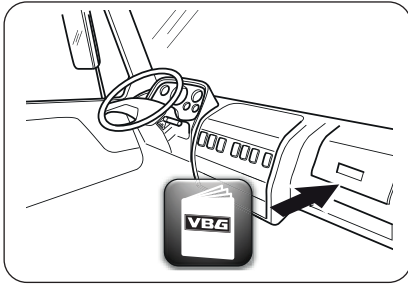

<b>DB 75V-3 .....</b>	<b>6</b>
<b>EDH-4 MAN .....</b>	<b>7</b>
<b>EDH-4 DAF .....</b>	<b>8</b>
<b>EDH-4 IVECO .....</b>	<b>9</b>
<b>EDH-4 MB .....</b>	<b>10</b>
<b>EDH-4 SCANIA .....</b>	<b>11</b>
<b>EDH-4 VOLVO/RVI .....</b>	<b>12</b>



**DB75V-3**

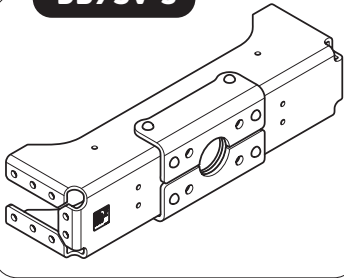

**16 x M16  
(10.9)**



**250 Nm**

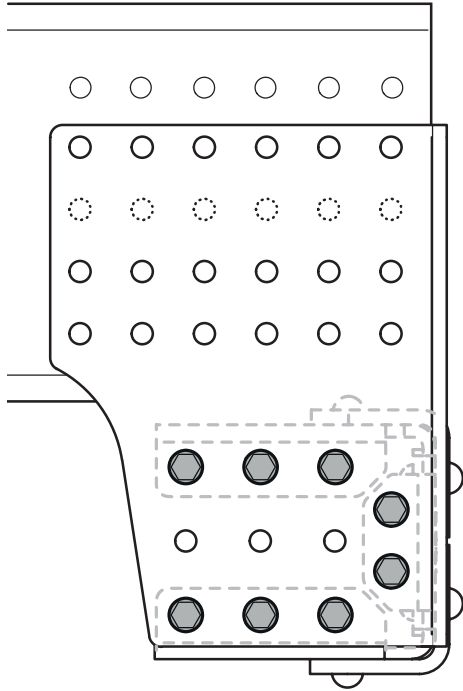



# EDH-4 MAN



24 x M14  
(10.9)



163 Nm

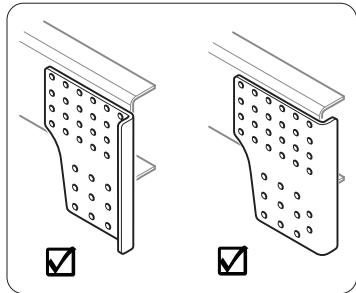

EDH-4 + EUP-180/  
EUP URSP 180-2



24 x M14 (10.9)



163 Nm

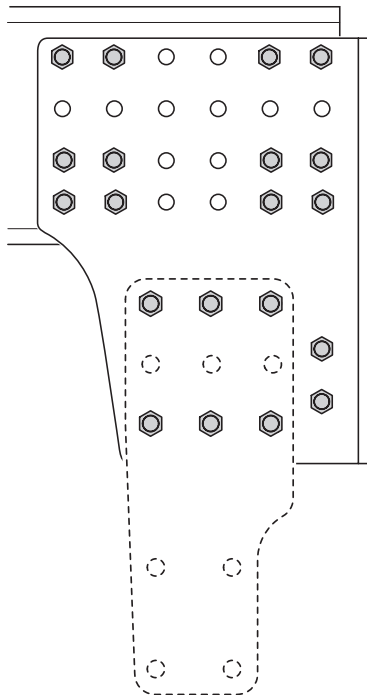
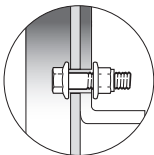
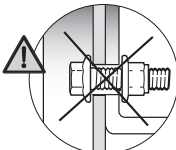

EUP URSP 180-2



38-364200

EUP 180 EUR 180

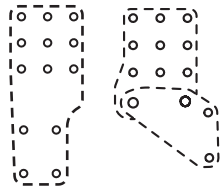

38-324100



**EDH-4 DAF**

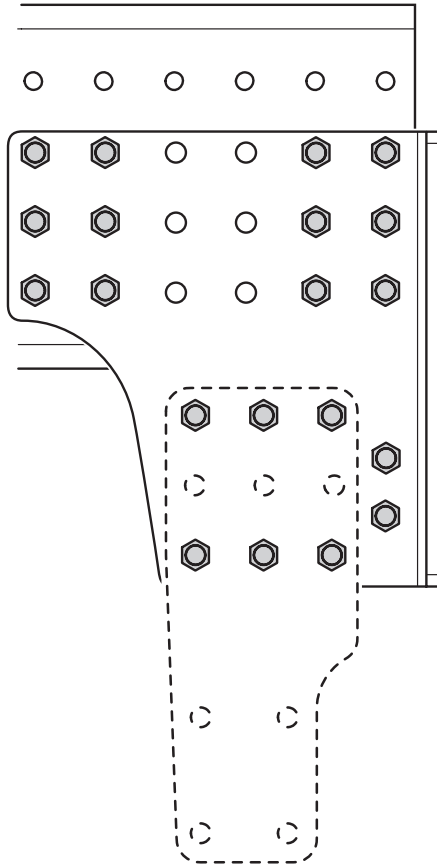
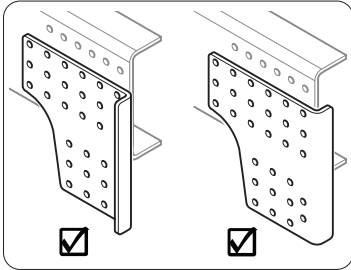

**24 x M16  
(10.9)**



**250 Nm**

**EUP URSP 180-2**



**38-364200**

**EUP 180 EUR 180**

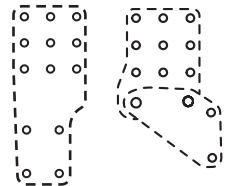

**38-324100**





## EDH-4 IVECO



24 x M14  
(10.9)



163 Nm

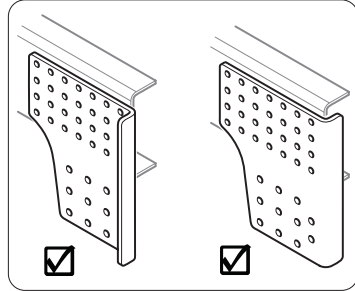

EDH-4 + EUP-180/  
EUP URSP 180-2



24 x M14 (10.9)

 163 Nm

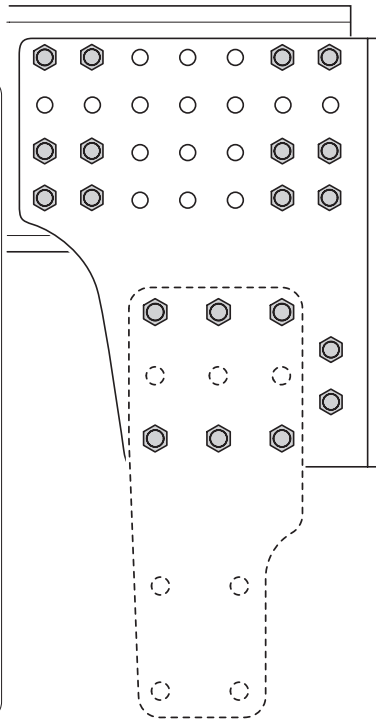
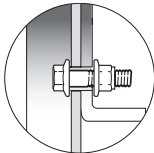
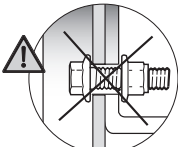

EUP URSP 180-2



38-364200

EUP 180 EUR 180

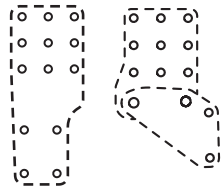

38-324100



### EDH-4 MB

**MB**

**MBN 10105**

**MBN 13023**

**24 x M16 (10.9)**



**225 Nm**

**+**

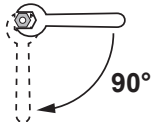

**20 x M16  
(10.9)**



**250 Nm**

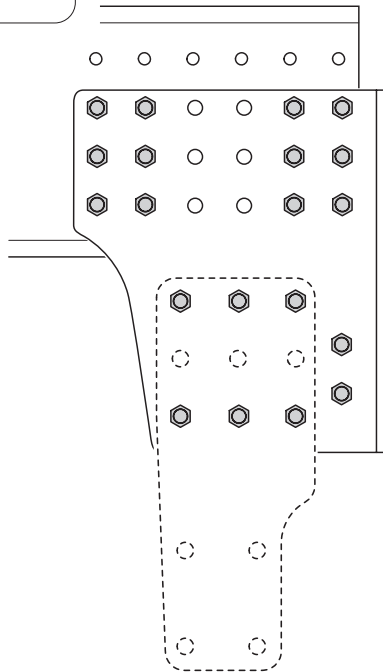
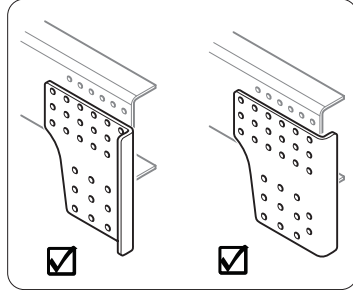

**EUP URSP 180-2**



**38-364200**

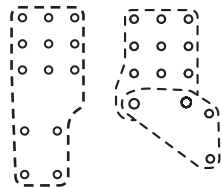

**EUP 180 EUR 180**



**38-324100**

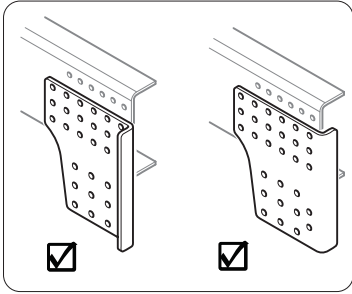

### EDH-4 SCANIA





**24 x M14  
(10.9)**

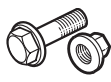

**163 Nm**

**EDH-4 + EUP-180/  
EUP URSP 180-2**





**24 x M14 (10.9)**

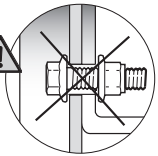
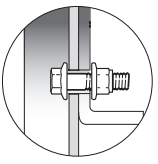
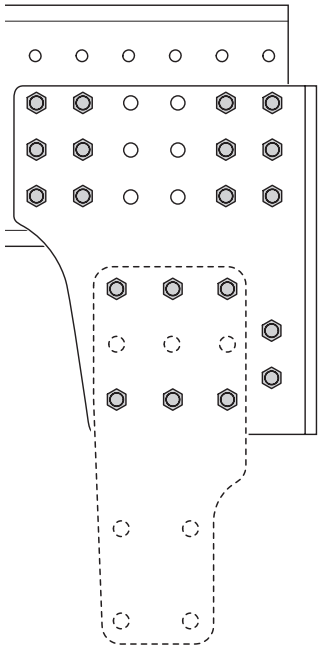

**163 Nm**







**EUP URSP 180-2**

**38-364200**

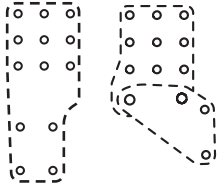
**EUP 180 EUR 180**

**38-324100**



## EDH-4 VOLVO/RVI



24 x M14  
(10.9)



163 Nm

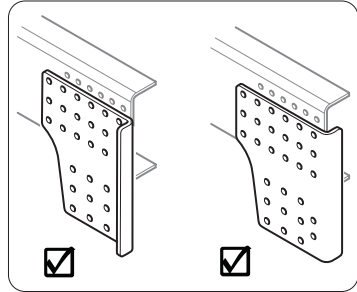

EDH-4 + EUP-180/  
EUP URSP 180-2



24 x M14 (10.9)

 163 Nm

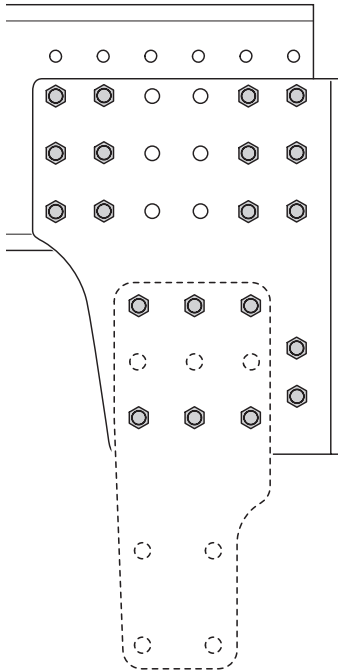
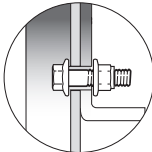
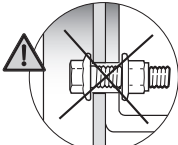

EUP URSP 180-2



38-364200

EUP 180 EUR 180

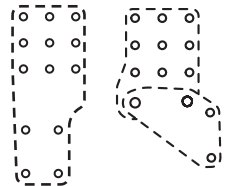

38-324100







