

MOUNTING INSTRUCTION

2019-07-05 38-238900c



09-073600

09-312900

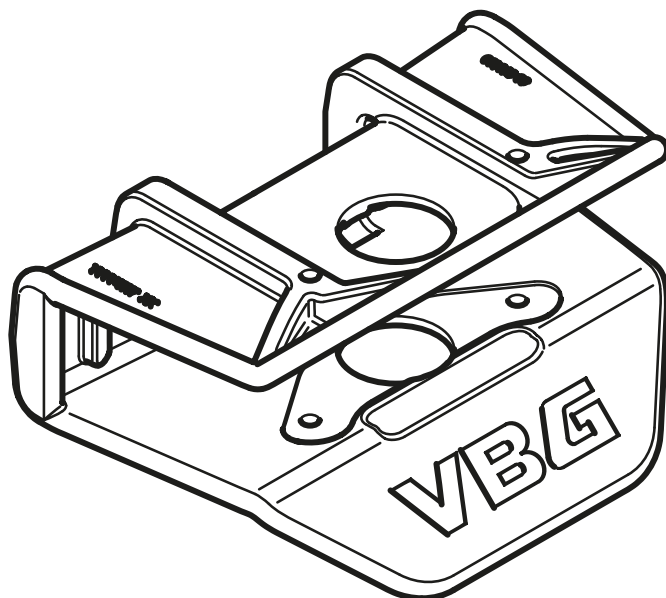

DE

Ersatzteil Fangmaul

DK

Reservedel Fangmund

EE

Varuosa haakeava

FI

Varaosa Kita

FR

Pièce de rechange mâchoire

GB

Spare part Guiding funnel

LV

Rezerves daļa, Satvērējs

NL

Reservedelen vangmuil

NO

Reservedel Fangåpning

PL

Części zamienne Szczęka zaczepu

RU

Запасная часть зев захвата

SE

Reservedel Fångmun



Montageanleitung
Monteringvejledning
Paigaldusjuhend
Asennusohje

Instructions de montage
Mounting instruction
Montāžas instrukcija
Montagehandleiding

Monteringsanvisning
Instrukcja montażowa
Указания по монтажу
Monteringsanvisning

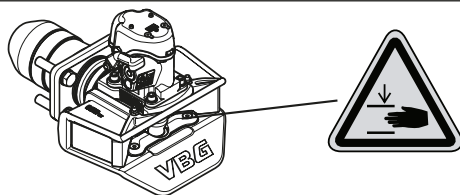

09-073600

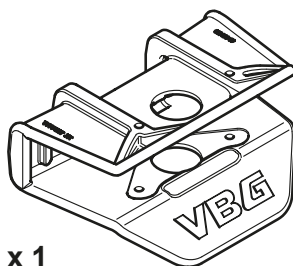
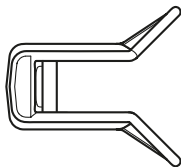

x 1

09-312900

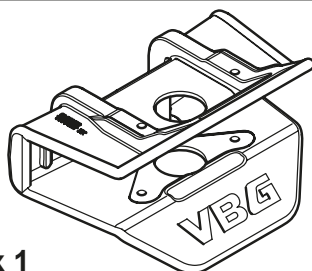
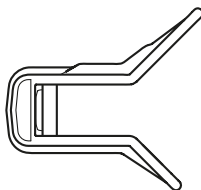

x 1

DE

Allgemeines

Wenn die Kupplung mit einem Luftservo oder AM-Mechanismus ausgestattet ist, muss die Luftzufuhr für den Ventilkasten unterbrochen werden, bevor an der Kupplung gearbeitet wird. *Vor der Montage alle Teile identifizieren. Montage und Wartung müssen sorgfältig und fachmännisch durchgeführt werden.*

DK

Generelt

Hvis koblingen er udstyret med luftservo eller AM-enhed, skal fødeluften til betjeningsventilen afbrydes, inden arbejdet med koblingen påbegyndes. *Kontroller at alle dele er til stede inden montering. Montering og service skal foretages omhyggeligt og fagmæssigt.*

EE

Üldist

Kui haakeseadis on varustatud pneumaatilise servojuhtimisega või AM-üksusega, siis tuleb klapikarpi edastatav õhuvool katkestada enne tööde alustamist haakeseadise kallal. *Määratlege kõik osad enne monteerimist. Paigaldus ja hooldus tuleb teostada hoolikalt ja professionaalselt.*

FI

Yleistä

Servolla tai AM-mekanismilla varustetussa kytkimessä paineilman tulo venttiilikoteloon on katkaistava ennen kytkimen huoltotöiden aloittamista. *Tunnista kaikki osat ennen asennusta. Asennus ja huolto on suoritettava huolellisesti ja ammattimaisesti.*

FR

Généralités

Si l'accouplement est équipé d'un servo pneumatique ou d'une unité AM, couper l'air d'alimentation vers la boîte à vannes avant de commencer le travail sur l'accouplement. *Identifier toutes les pièces avant le montage. Le montage et l'entretien doivent être effectués avec le plus grand soin et selon les règles de l'art.*

GB

General

If coupling is fitted with a Power Actuator or AM unit, the supply air to the valve box must be disconnected before working on the coupling. *Identify all parts before installation. Installation and service should be carried out carefully and professionally.*

LV

Vispārēja informācija

Ja sakabe ir aprīkota ar pneimatisko servosistēmu vai ar AM mehānismu, pirms darba sākšanas ar sakabi obligāti jānoslēdz gaisa padeve uz manevrēšanas ventīli. *Pirms montāžas identificējiet visas detaļas. Montāža un serviss jāveic rūpīgi un profesionāli.*

NL

Algemeen

Als de koppeling met luchtservo of AM-unit is uitgerust, moet u de voedingslucht naar de kleppenkast onderbreken voordat u met de werkzaamheden aan de koppeling begint. *Voor de montage moet u alle onderdelen identificeren. Voer montage en service zorgvuldig en deskundig uit.*

NO

Generelt

Hvis koblingen er utstyrt med luftservo eller AM-enhet, skal mateluften til ventilboksen brytes før arbeidet med koblingen påbegynnes. *Identifiser alle deler før montering. Montering og service skal utføres nøyaktig og fagmessig.*

PL

Informacje ogólne

Jeżeli zaczepek wyposażony jest w siłownik pneumatyczny lub w urządzenie AM, przed przystąpieniem do pracy przy zaczepek należy odciąć dopływ powietrza zasilającego do skrzynki zaworu. *Zapoznaj się z poszczególnymi częściami przed przystąpieniem do montażu. Czynności montażowe i serwisowe należy wykonywać dokładnie i fachowo.*

RU

Общая информация

Если соединение оснащено воздушным серво или блоком AM, то подающий воздух к коробке клапанов должен быть перекрыт перед началом работ с соединением. *Перед монтажом проверьте наличие всех деталей. Монтаж и обслуживание должны осуществляться тщательно и профессионально.*

SE

Allmänt

Är kopplingen försedd med luftservo eller AM-enhet skall matarluften till ventillådan brytas innan arbetet med kopplingen påbörjas. *Identifiera alla delar före montering. Montering och service skall utföras noggrant och fackmannamässigt.*



1.

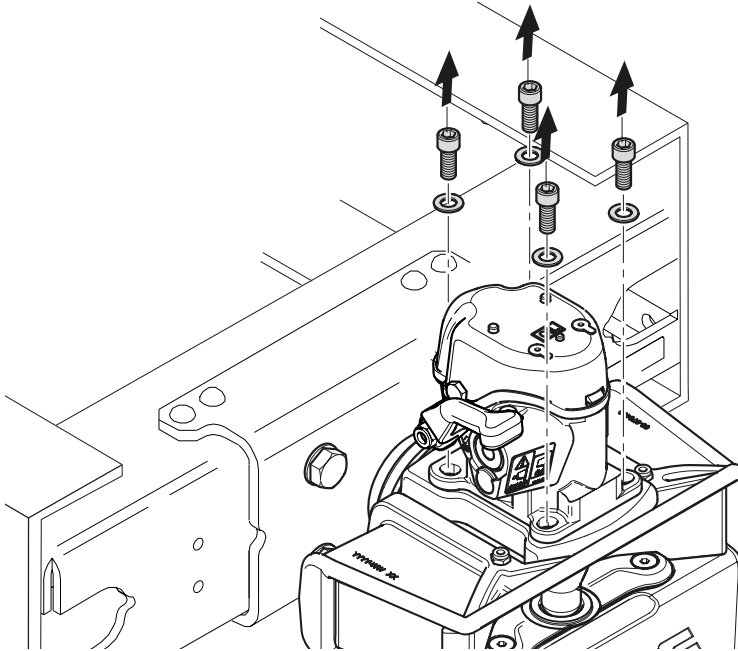

2.

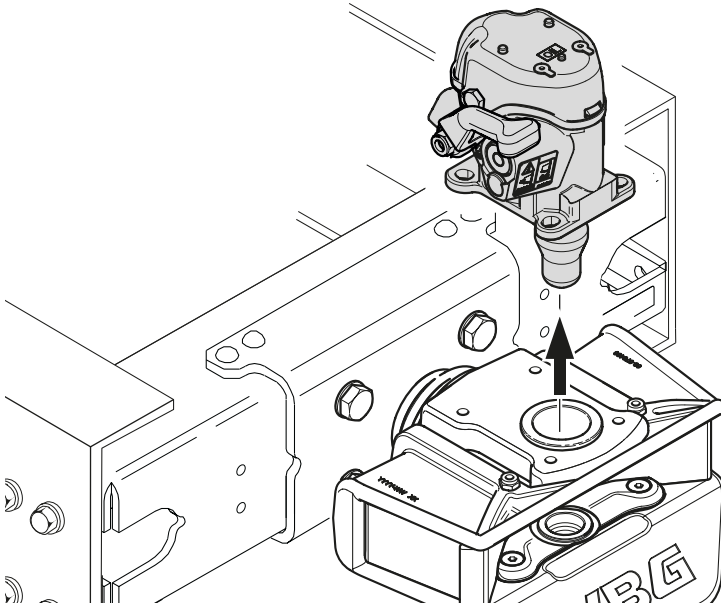

3.

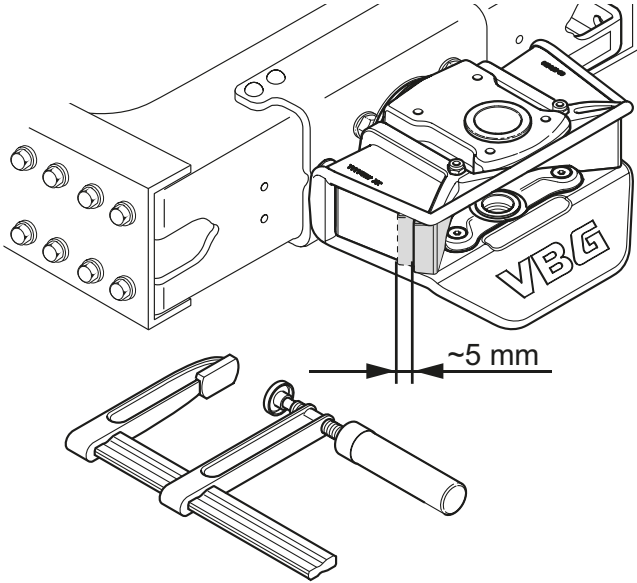

4.

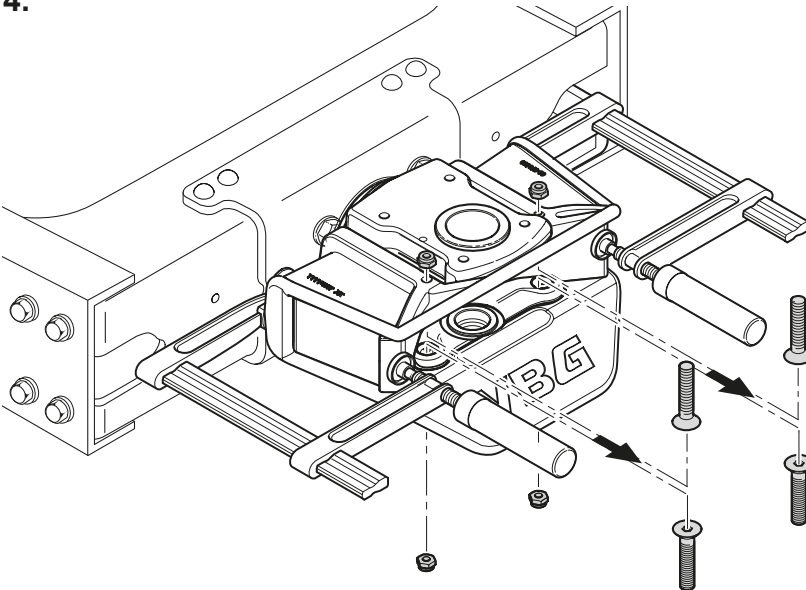

5.

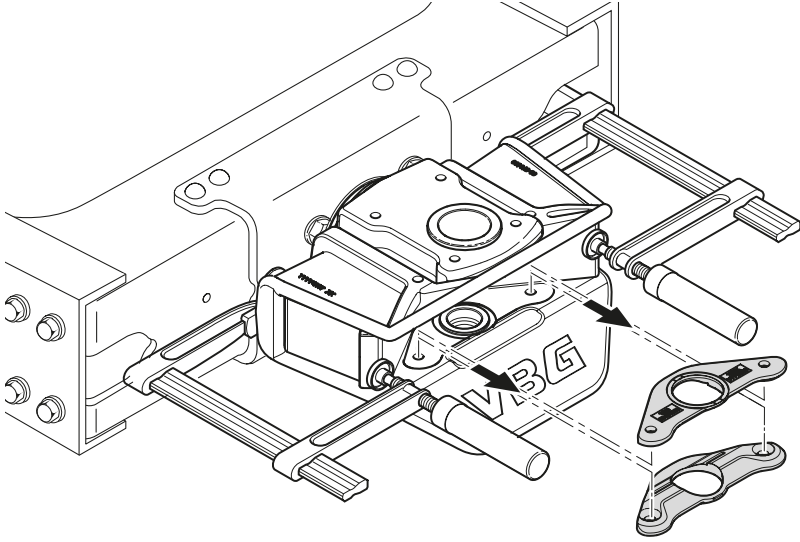

6.

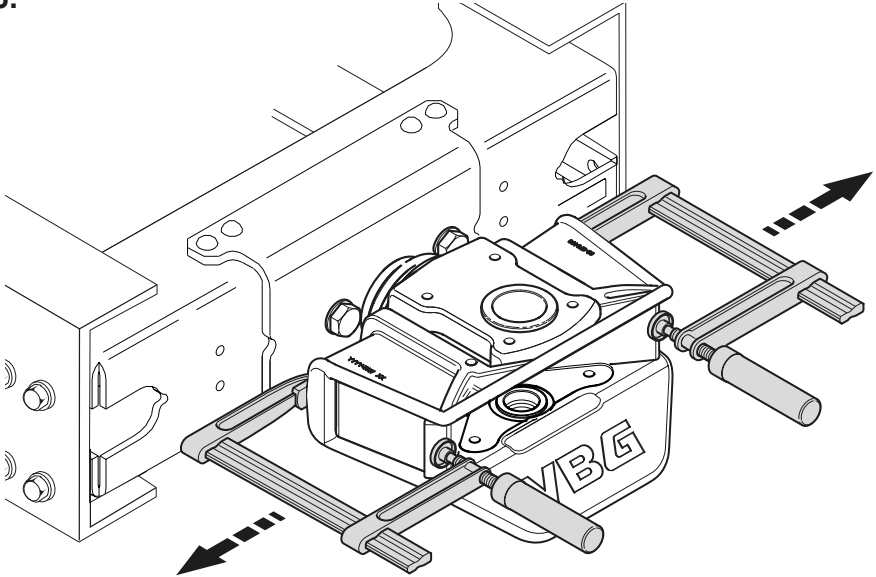

7.

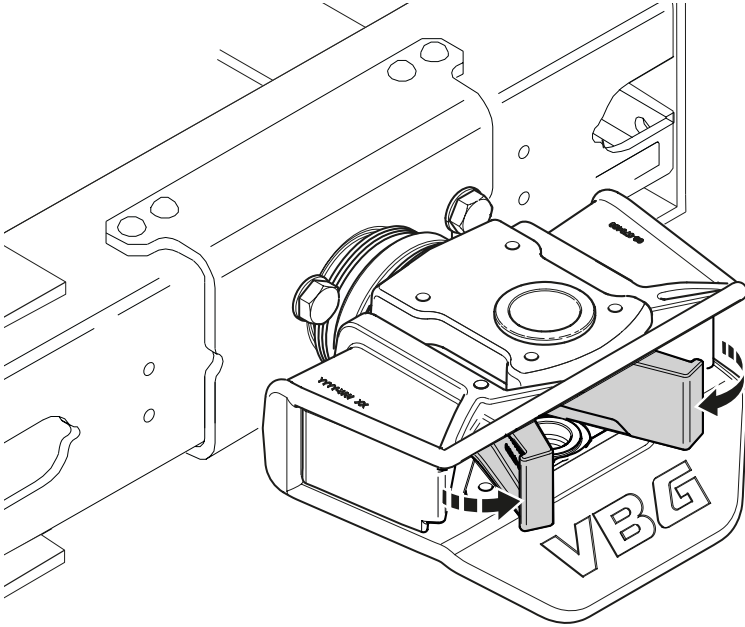

8.

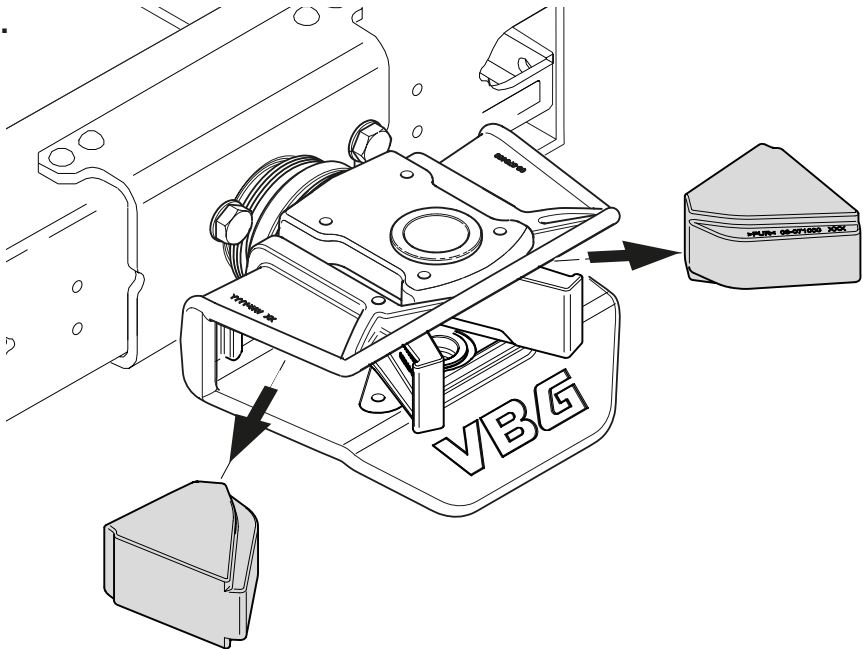

9.

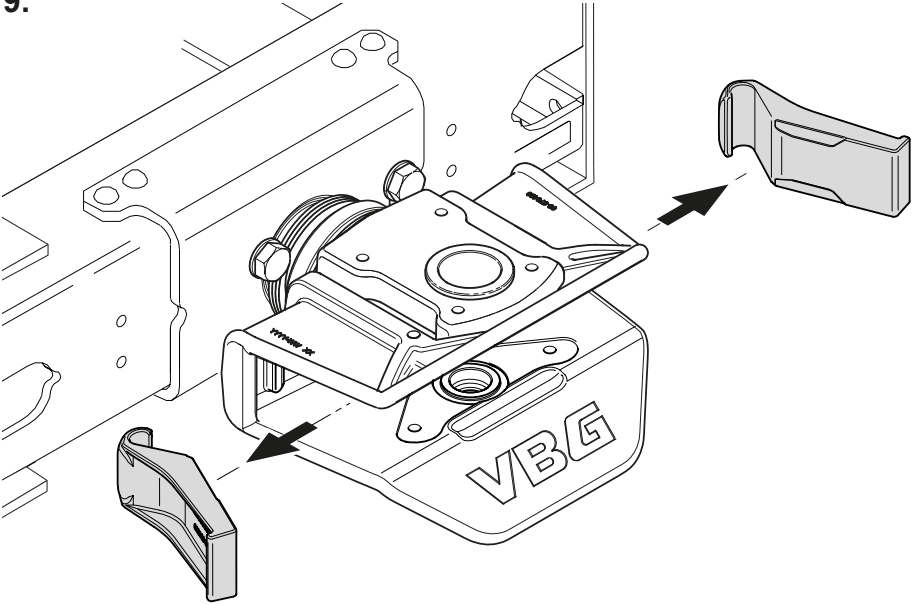

10.

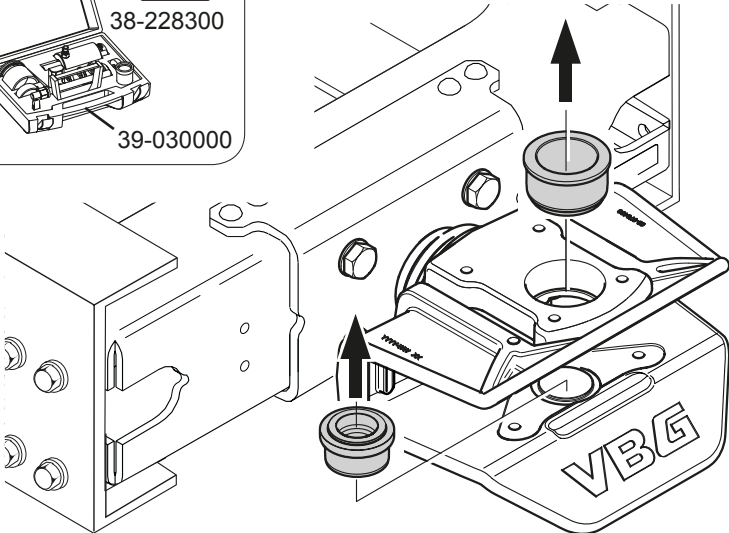

11.

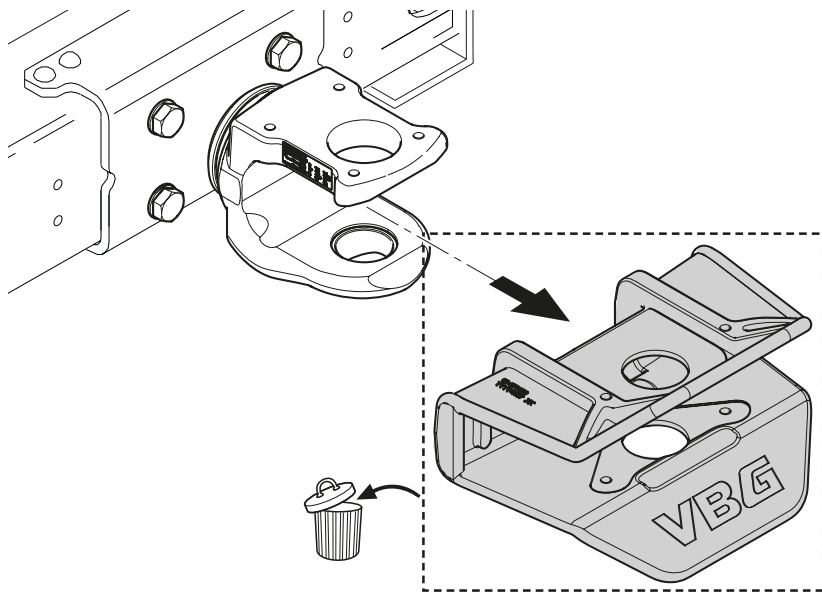

12.

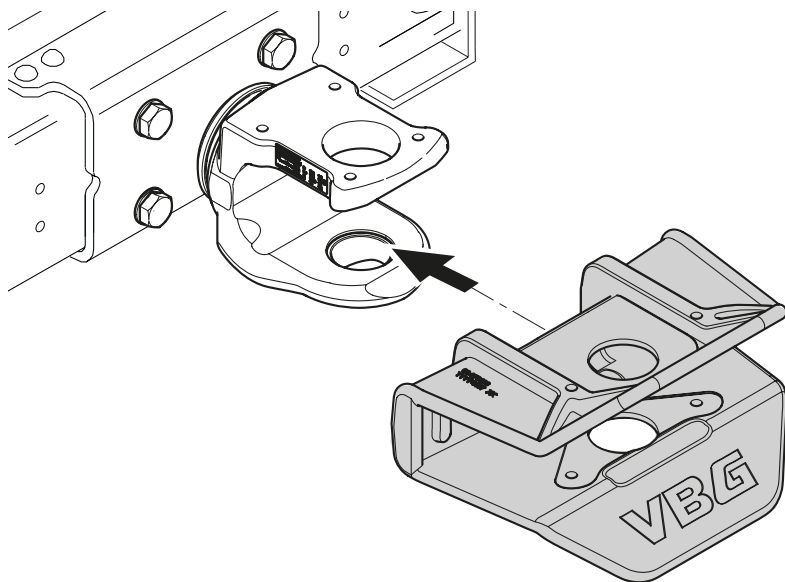

13.

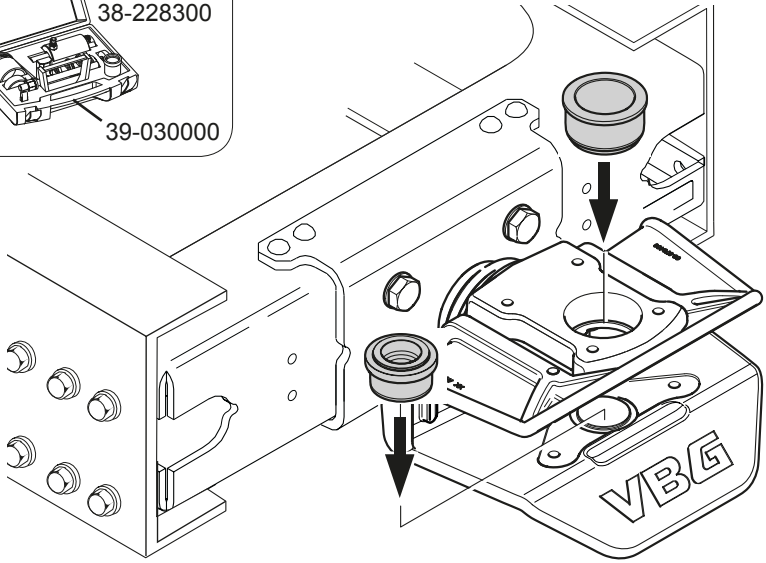

14.

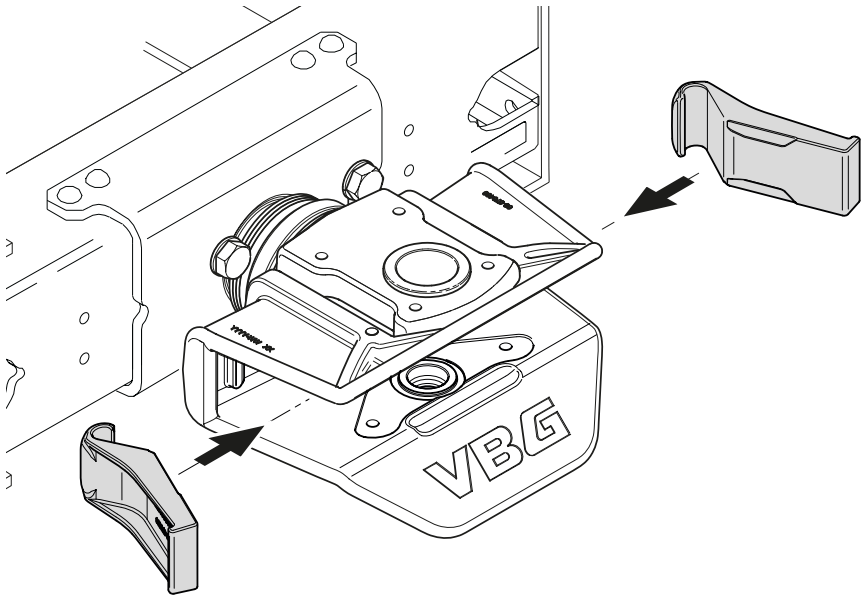

15.

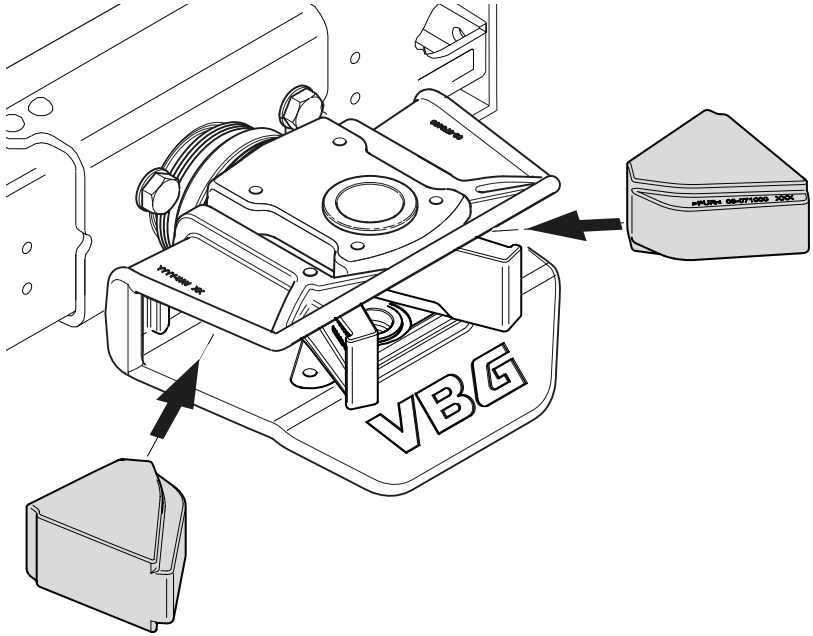

16.

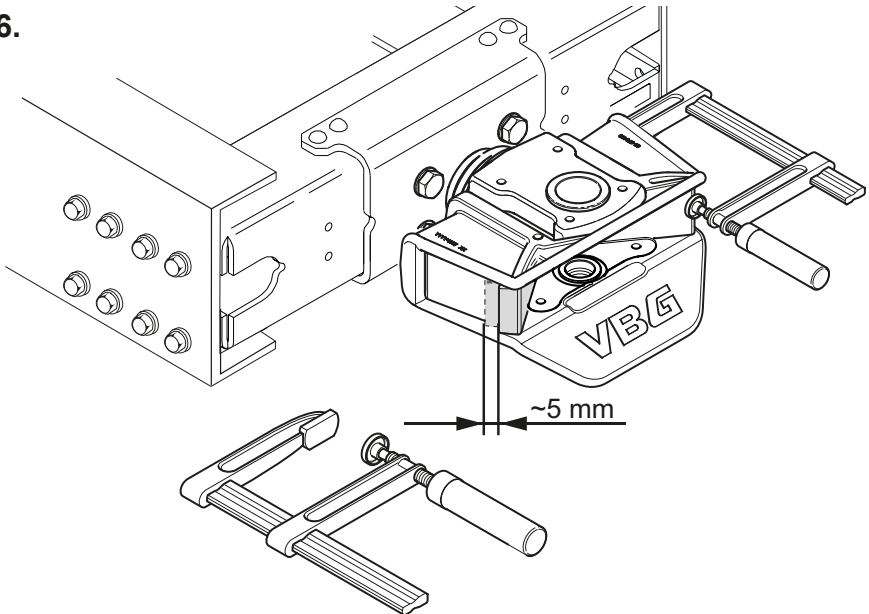

17.

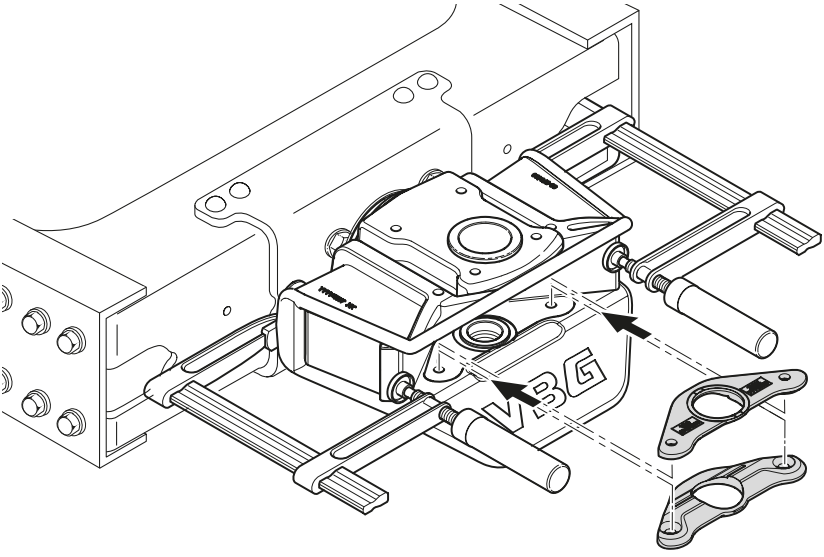

18.

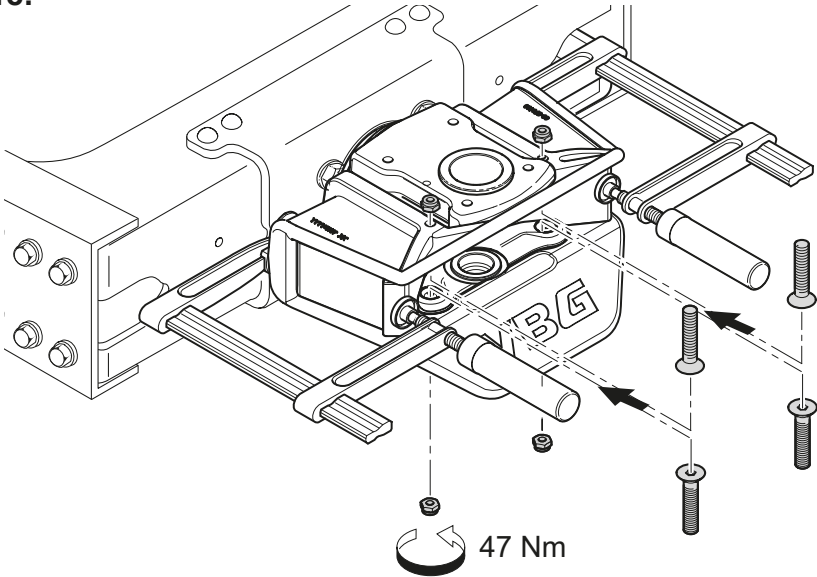

19.

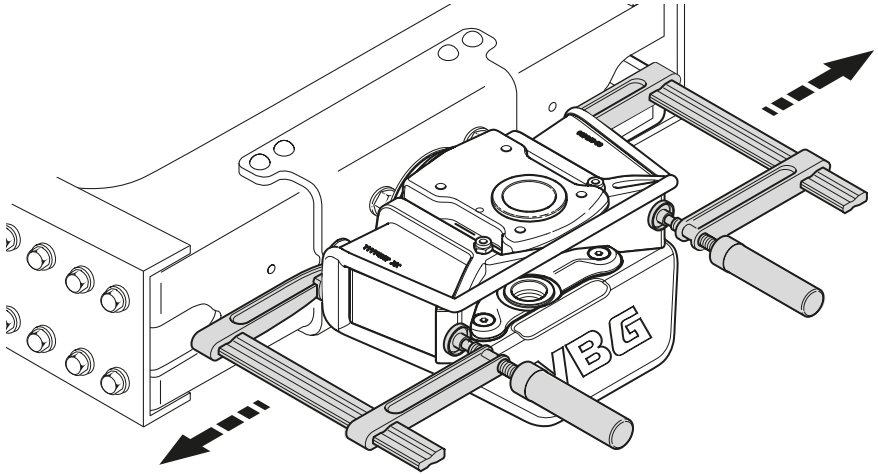

20.

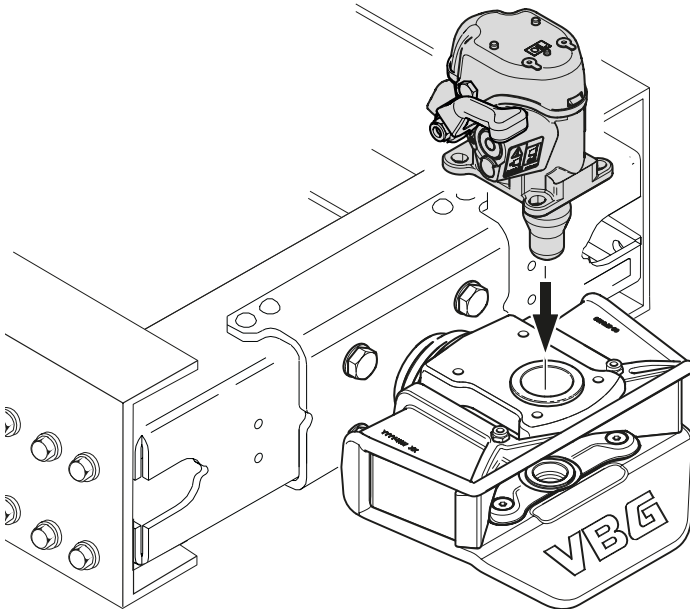

21.

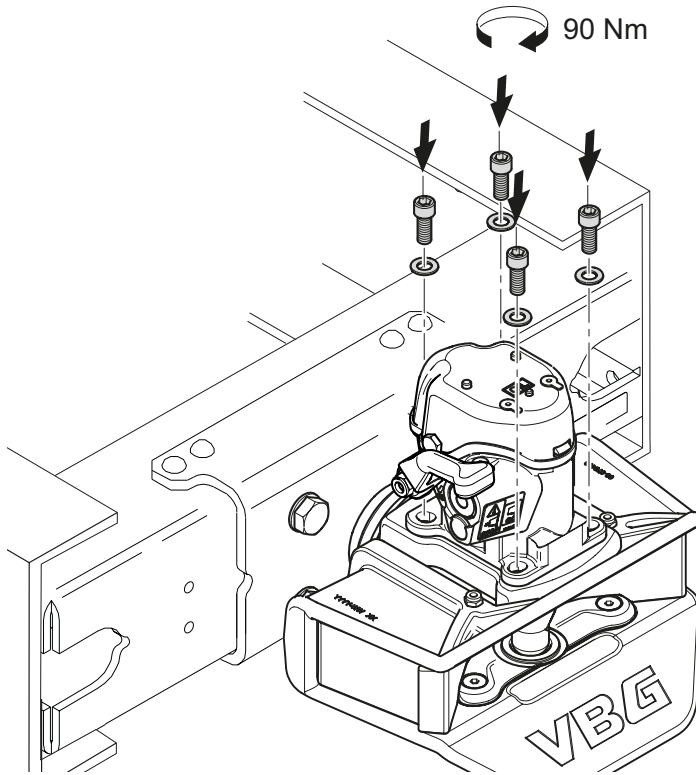

Member of VBG Group

www.vbg.eu



The strong connection