

MOUNTING INSTRUCTION

2017-05-11 38-216600b

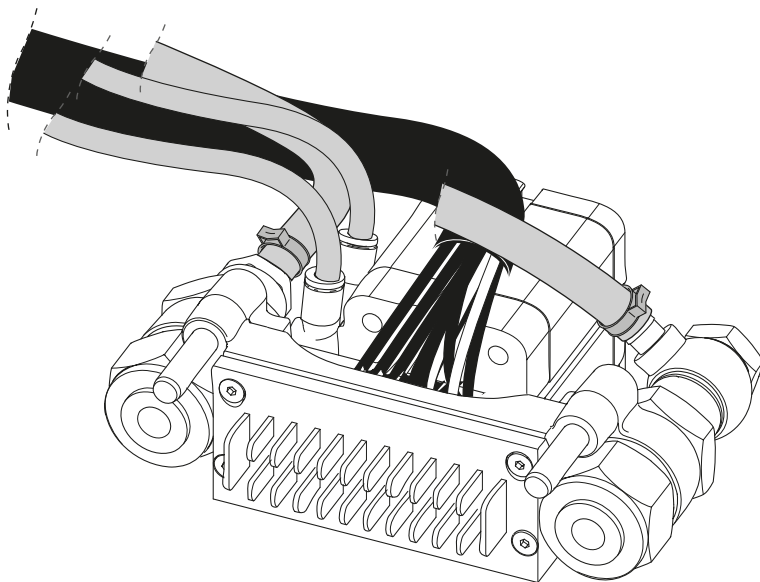

08-100100



DE Strom-Luftkupplung

DK El-luftkobling

FI Sähkö-Ilmaliitäntä

GB Power-Air coupling

LV Elektrības un gaisa sakabe

NO El-Luftkobling

PL Połączenie elektryczno-pneumatyczne

SE El-Luftkoppling



Montageanleitung
Monteringsvejledning
Asennusohje

Mounting instruction
Montāžas instrukcija
Monteringsanvisning

Instrukcja montażowa
Monteringsanvisning

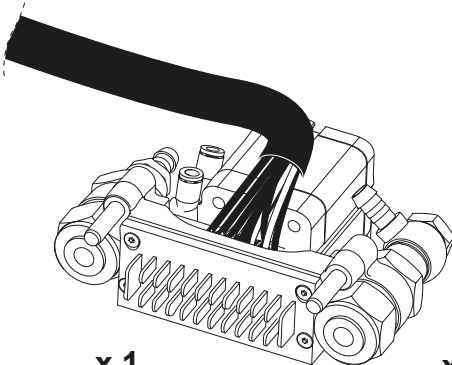
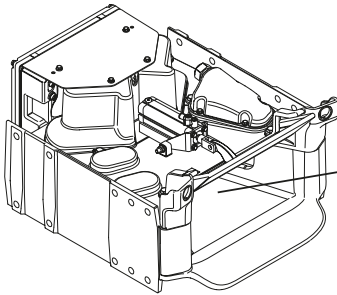

x 1

x 2

x 2

x 3

x 4

DE

Allgemeines

Montage von Ersatzteil Strom-Luftkupplung. *Vor der Montage alle Teile identifizieren. Montage und Wartung müssen sorgfältig und fachmännisch durchgeführt werden. Die Anweisungen befolgen.* Nach der Montage müssen zur Funktionskontrolle eine An- und eine Abkupplung durchgeführt werden. Folgen Sie den Anweisungen unter „Ankuppeln“ und „Abkuppeln“ im Fahrerhandbuch.



Bei allen Arbeiten im Inneren der Kupplung müssen sowohl Druckluft- als auch Stromversorgung unterbrochen werden, um Verletzungen/Beschädigungen vorzubeugen.

DK

Generelt

Montering af reservedelen El-luftkobling. *Identificer alle dele før montering. Montering og servicering skal udføres omhyggeligt og håndværksmæssigt korrekt. Følg anvisningerne.* Efter montering skal der foretages en til- og frakobling mhp. at kontrollere funktionaliteten. Følg instruktionerne for "Tilkobling" og "Frakobling" som beskrevet i Førermanualen.



Ved alt arbejde inde i koblingen skal både luft og el afbrydes/slukkes aht. risikoen for skader.

FI

Yleistä

Varaosan Sähkö-Ilmaliitäntä. *Tunnista kaikki osat ennen asennusta. Asennus ja huolto on suoritettava huolellisesti ja ammattimaisesti. Noudata ohjeita.* Asennuksen jälkeen toiminta on tarkastettava tekemällä irti- ja kiinnitykentä. Noudata Kuljettajan ohjekirjassa annettuja "Kiinnitykentä" ja "Irtikytkentä" -ohjeita.



Kaikkien kytkimeen liittyvien töiden ajaksi on tapaturmavaaran vuoksi, sekä paineilla- että sähkönsyöttö katkaistava/suljettava.

GB

General

Installation of spare part Power-Air coupling. *Identify all parts before installation. Installation and service shall be carried out carefully and professionally. Follow the instructions.* Connect and disconnect after the installation to check functionality. Follow the instructions for "Connection and Disconnection" in the Driver Manual.



The air and power must be disconnected/switched off during all work on the coupling to prevent the risk of pinch injuries.

LV

Vispārēja informācija

Rezerves detaļu montāža Elektrības un gaisa sakabe. *Pirms montāžas identificējiet visas detaļas. Montāža un serviss ir jāveic rūpīgi un profesionāli. Sekojiet norādījumiem.* Pēc montāžas pārbaudiet, vai darbojas savienojot un atvienojot. Sekojiet instrukcijām par „Pievienošanu” un „Atvienošanu” Vadītāja rokasgrāmatā.



Lai neradītu risku, darba laikā savienojumā jābūt atslēgtam gan gaisa, gan elektriskajam savienojumam.

NO

Generelt

Montering av reservedel EI-Luftkobling. *Identifiser alle deler før montering. Montering og service skal utføres nøyaktig og fagmessig. Følg anvisningene.* Etter montering skal det foretas en til- og frakopling for å kontrollere funksjonen. Følg anvisninger for "Tilkopling" og "Frakopling" i Førerhåndboken.



Ved alt arbeid inne i koplingen skal så vel luft som el brytes/slås av på grunn av risikoen for skade.

PL

Informacje ogólne

Montaż części zamiennej Połączenie elektryczno-pneumatyczne. *Zapoznaj się z poszczególnymi częściami przed przystąpieniem do montażu. Czynności montażowe i serwisowe należy wykonywać dokładnie i fachowo. Stosuj się do instrukcji.* Po zamontowaniu należy przyłączyć i odłączyć przyczepę w celu sprawdzenia działania. Stosuj się do instrukcji „Przyłączanie” i „Odłączanie” w Podręczniku dla kierowcy.



W razie wykonywania jakichkolwiek czynności przy zaczepie należy odłączyć/wyłączyć zarówno dopływ powietrza, jak i prądu ze względu na ryzyko odniesienia obrażeń.

SE

Allmänt

Montering av reservdel EI-Luftkoppling. *Identifiera alla delar före montering. Montering och service skall utföras noggrant och fackmannamässigt. Följ anvisningarna.* Efter montering skall en till- och fränkoppling göras för att kontrollera funktionen. Följ instruktioner för "Tillkoppling" och "Fränkoppling" i Förmanualen.



Vid allt arbete inne i kopplingen ska såväl luft som el brytas/stängas av på grund av skaderisken.



1.

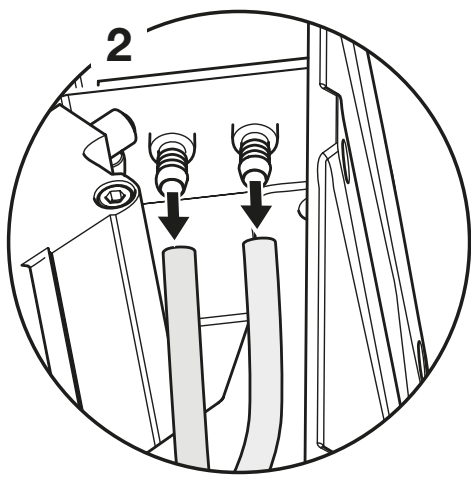
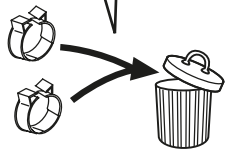
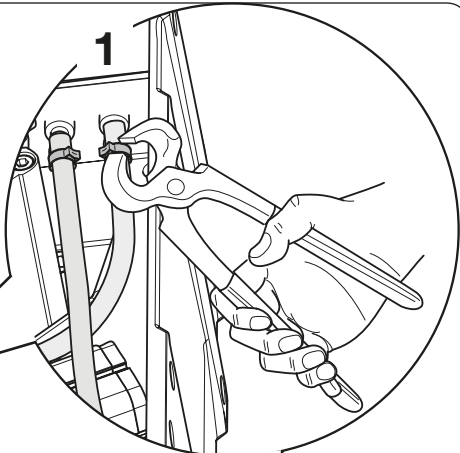
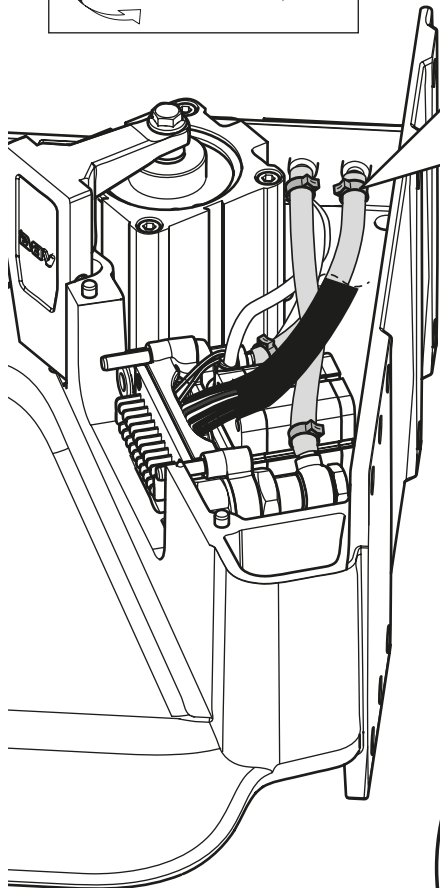
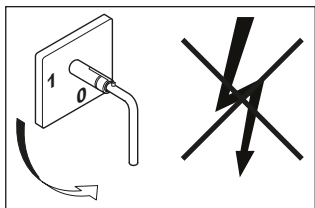

2.

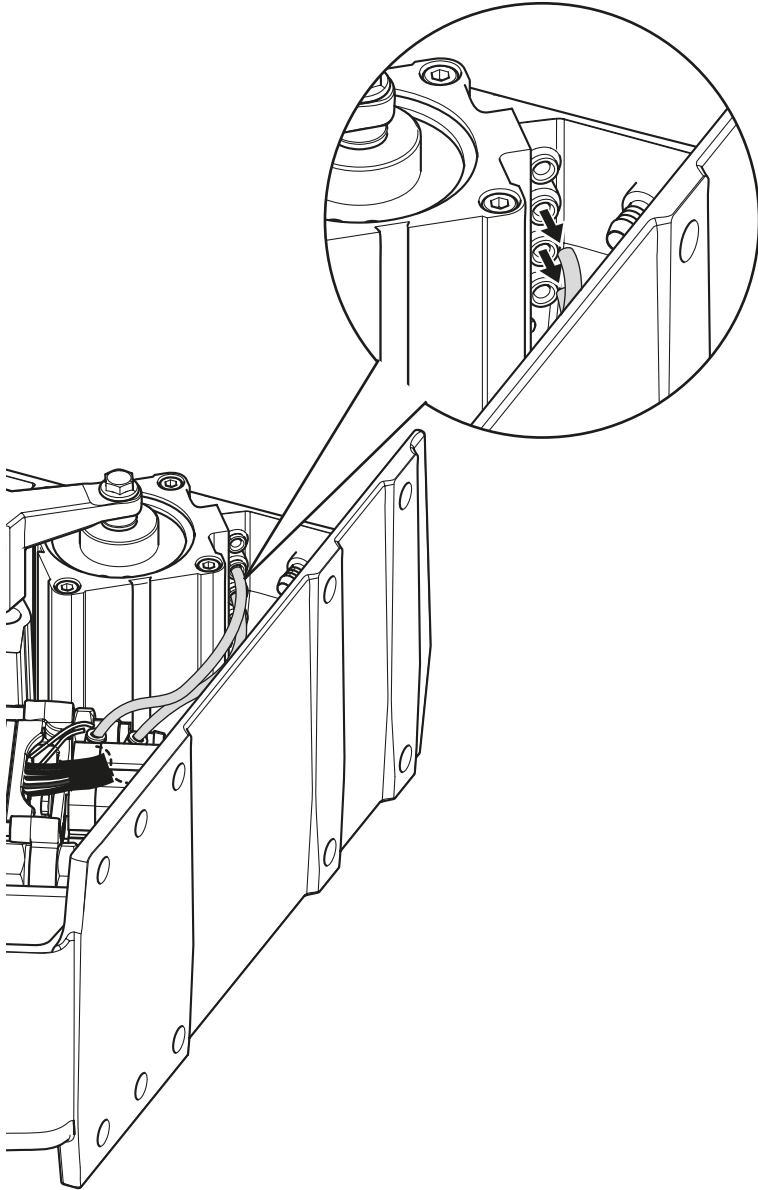

3.

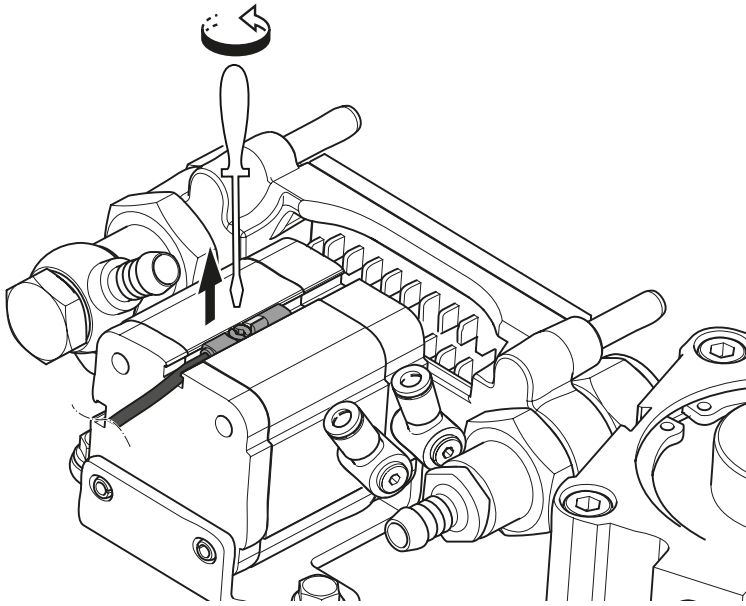

4.

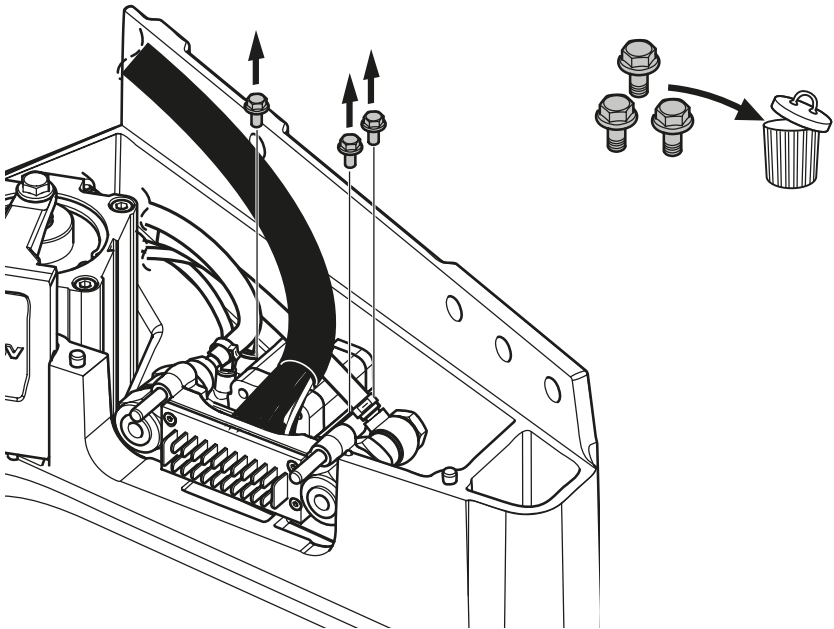

5.

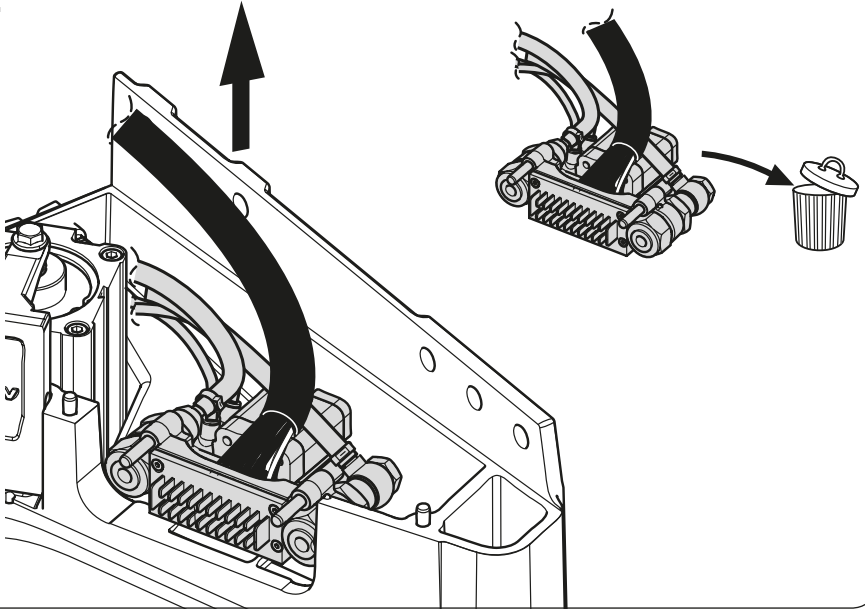

6.

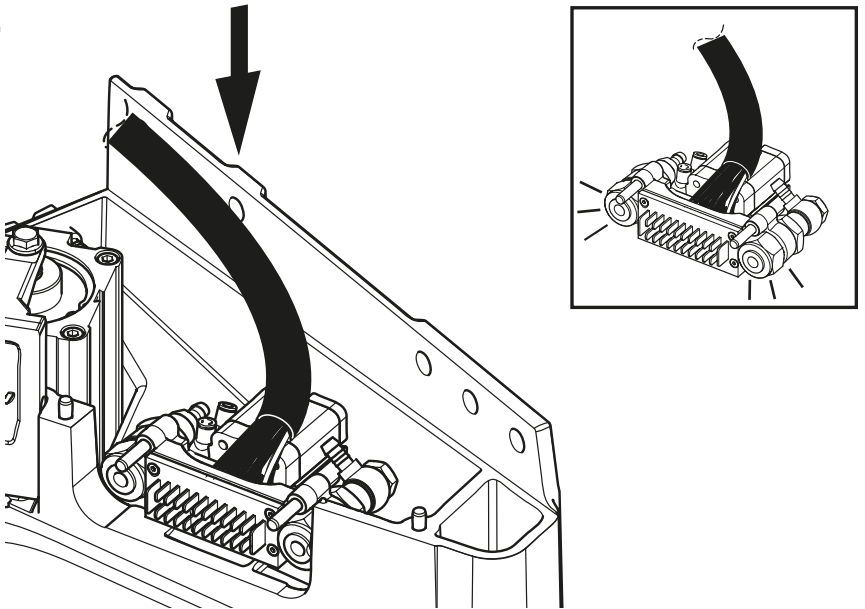

7.

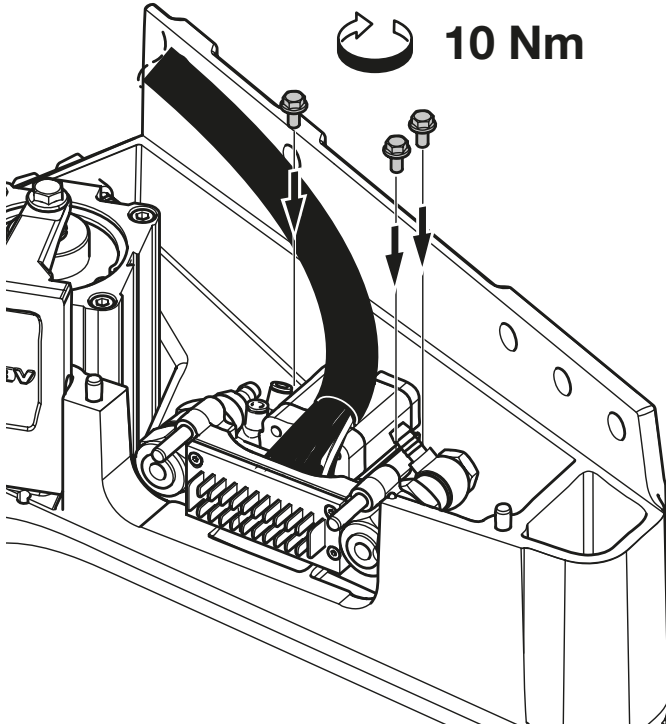

8.

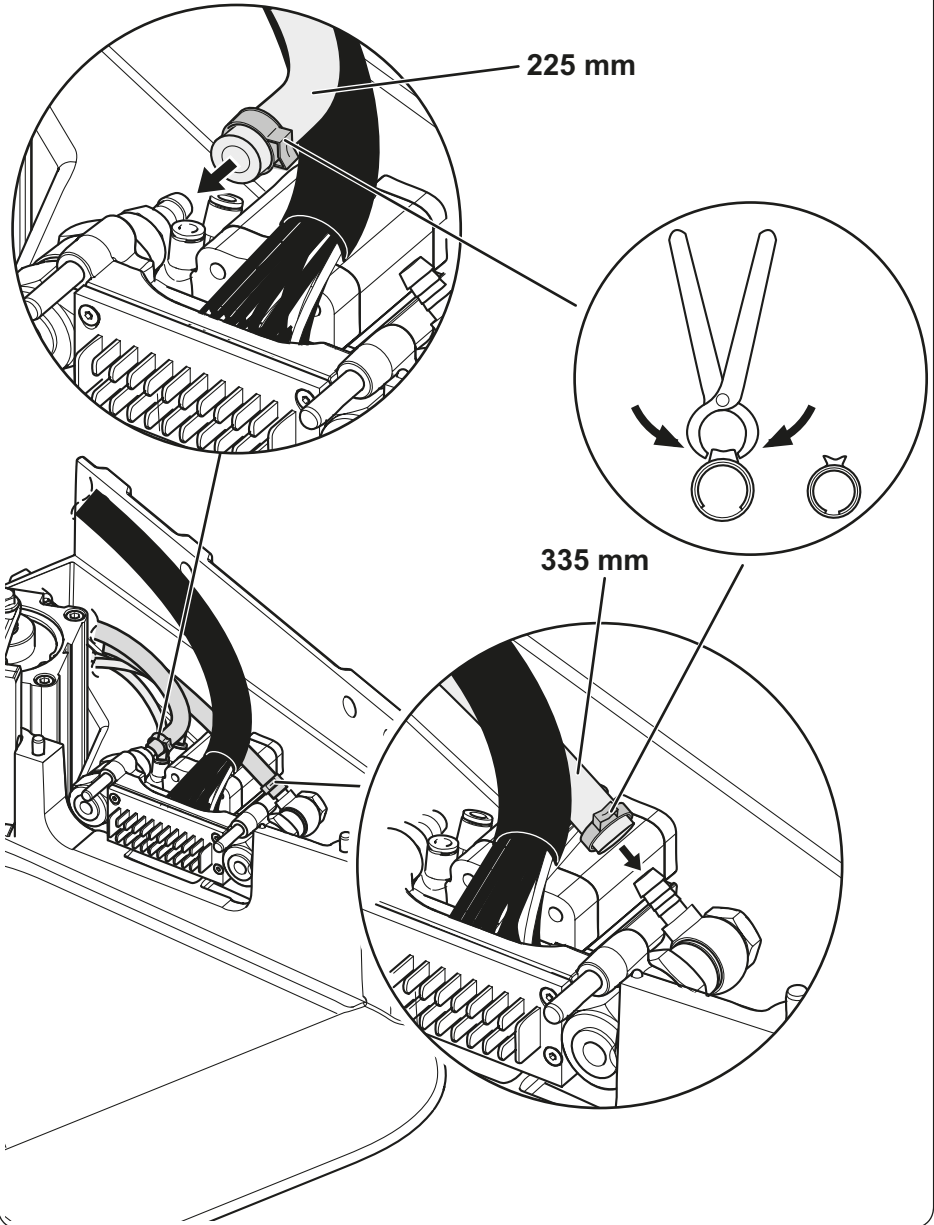

9.

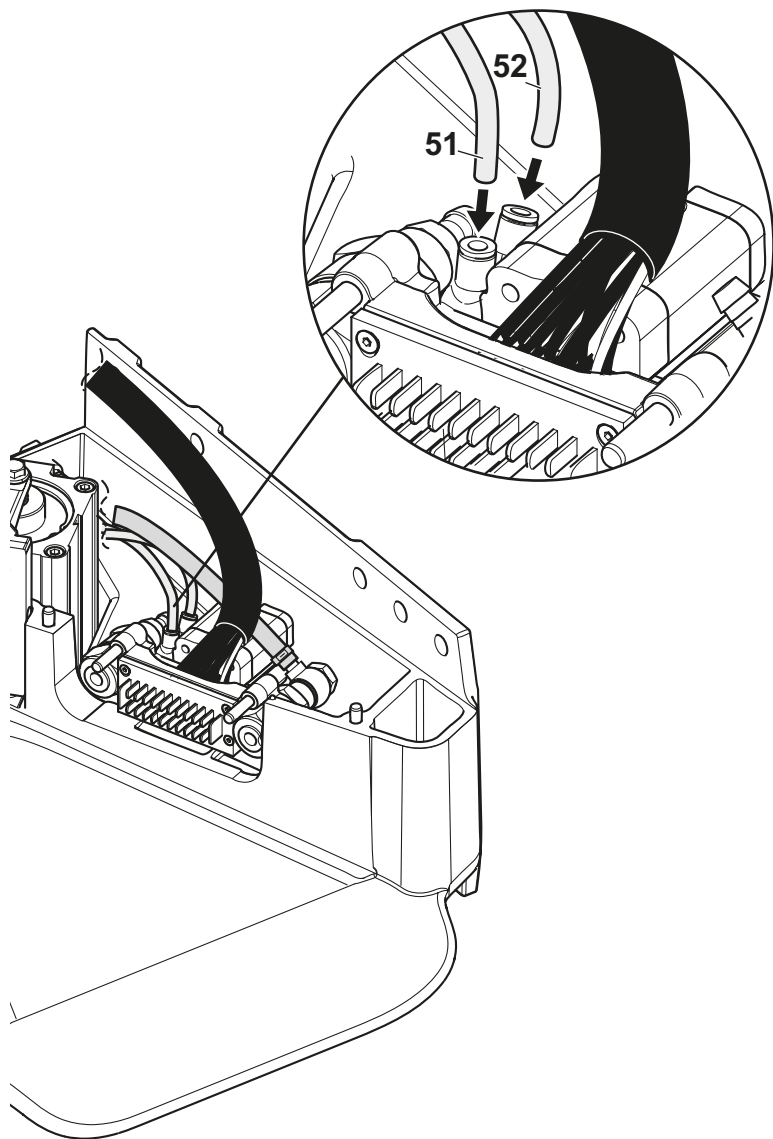

10.

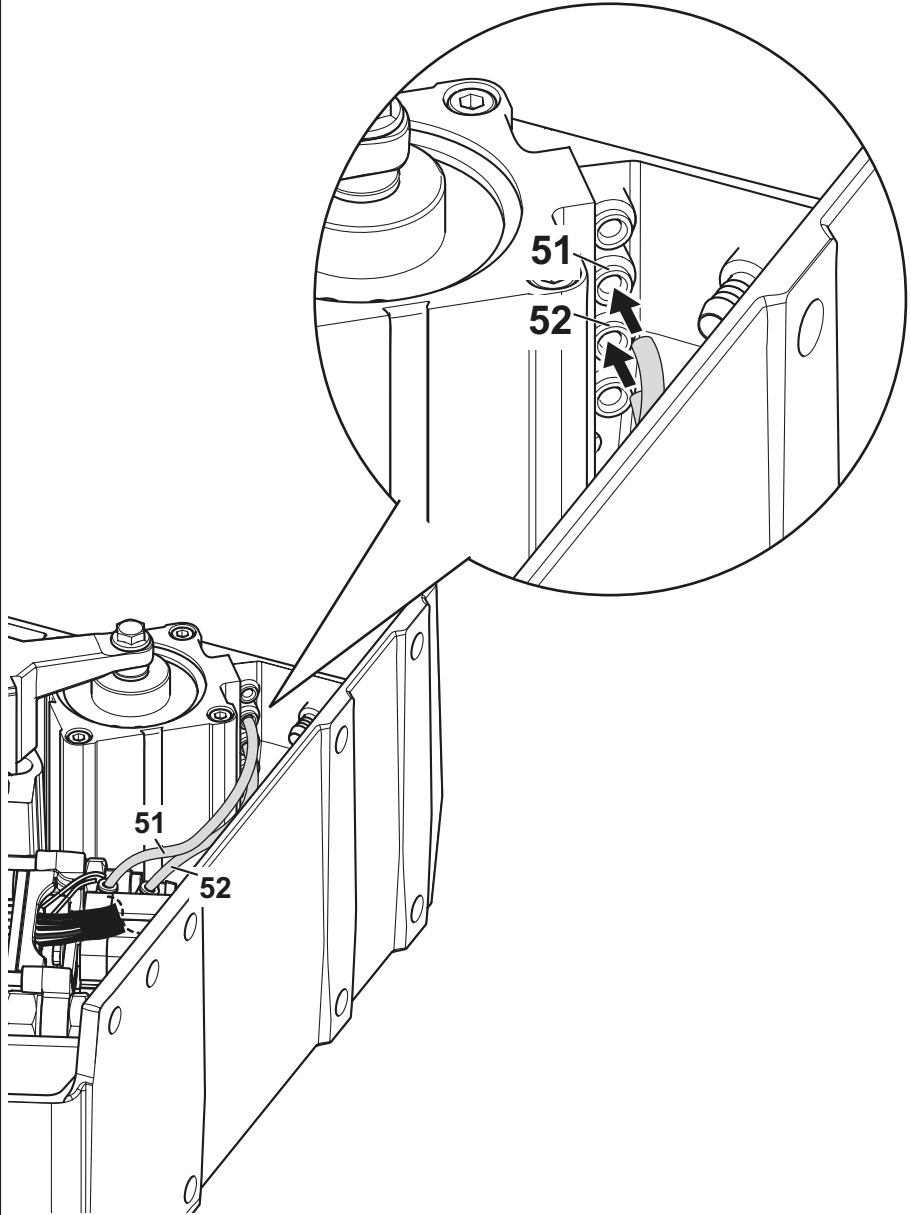

11.

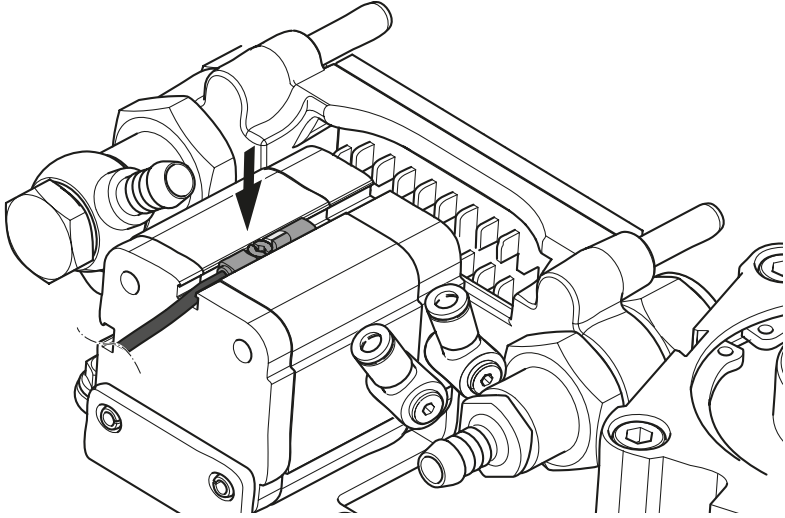

12.

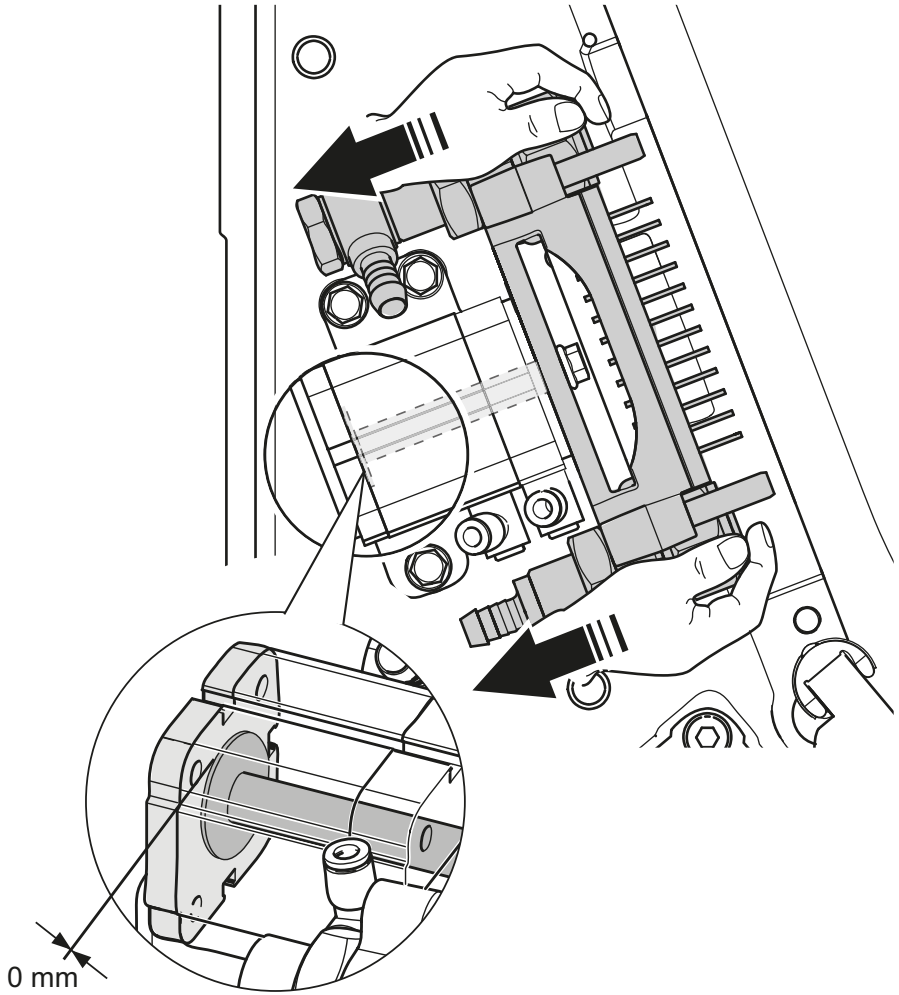

13.

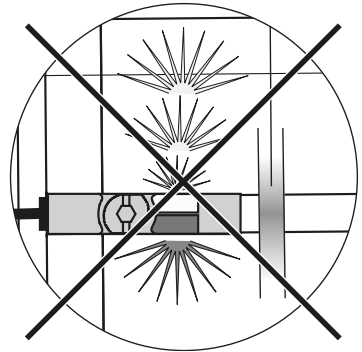
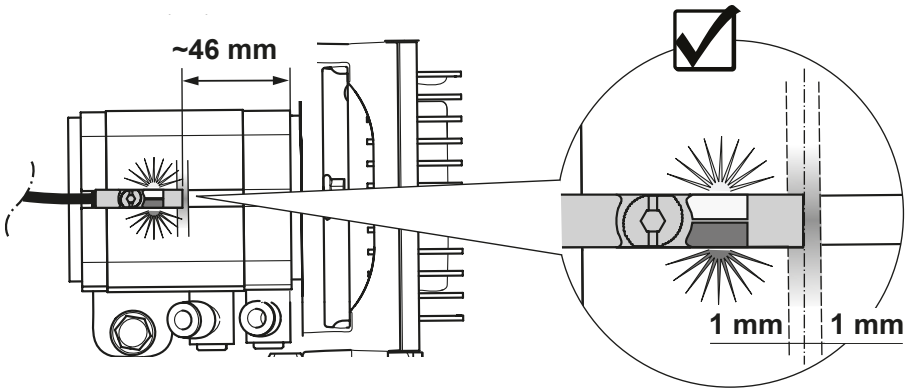
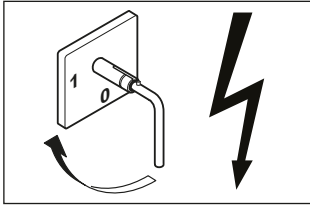

14.

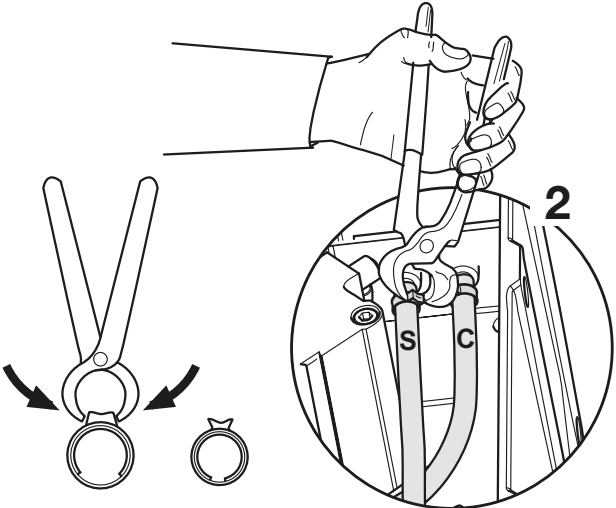
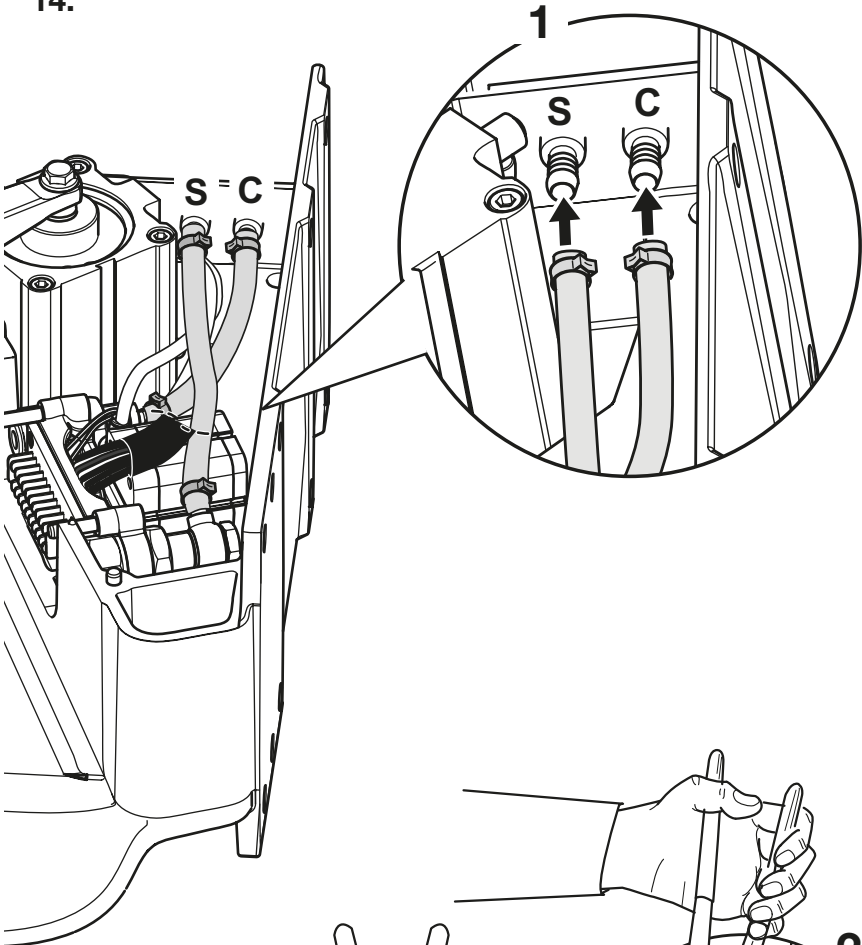

Member of VBG Group

www.vbg.eu



The strong connection